

PO 403

GENERAL KNOWLEDGE

GETTING STARTED

Read chapter 2 in the level 2 Handbook, sections 1 to 4. It is a good idea to read the chapter once as an introduction to the material and then a second time to better absorb the information.

ACTIVITY ONE

This activity deals with responsibilities of the Air Cadet League and DND. Complete the following crossword from the clues provided:

Across

1. Figure 2-1 outlines the channels of communication between the Air Cadet League and DND. The person at DND who communicates with the National League Headquarters is the _____ of Cadets.
2. The Air Cadet League and the Department of National Defence have a _____ to share responsibilities.
3. The Provincial Committee assists in the formation and _____ of squadron sponsoring committees and squadrons.
4. The League is responsible for _____ (2 words) with the community.
5. Training of CIC Officers from your squadron _____ is conducted by DND.
6. Local sponsoring committees are expected to _____ the squadrons.
7. DND is responsible for _____ or the squadron.
8. The League is responsible for providing _____ and facilities not provided by DND.
9. DND provides _____ for summer camp.

DOWN

1. DND is responsible for _____.
2. DND is responsible for _____.
3. The head of the squadron sponsoring committee is called a _____.

4. The head position of the Air Cadet League of Canada is called the _____.
5. The Air Cadet _____ is governed by a National Board of Directors made up of 55 Canadians from all 10 provinces.
6. DND is responsible for _____ of the squadron.
7. The National Air Cadet League office is located in _____.
8. The DND provides each cadet with a _____.
9. The Air Cadet League is divided into three levels. The top level is the _____ level.

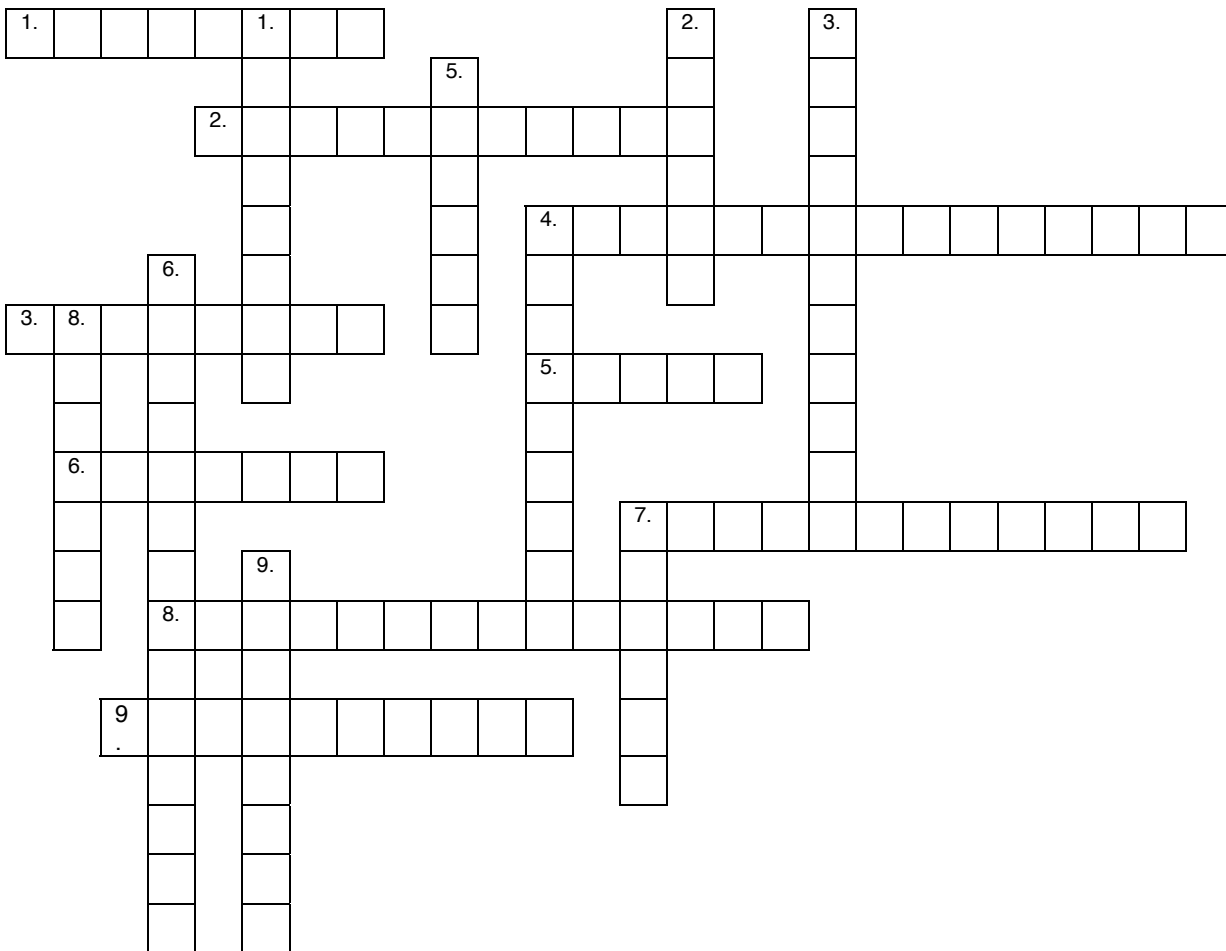

ACTIVITY TWO

Identify the Royal Canadian Sea Cadet Rank Insignia:

1) Unscramble the following Sea Cadet Ranks and then match them with the rank insignia picture.

1. inglade detac

2. decta eifch tepty icferof 2nd aclss

3. lbae edact

4. fiqualide tedac yetpt cifrefo 1st sacls

5. adect ypett ecifrof 2nd ssalc

6. aedct fiech etpty ociffer 1st asscl

7. daect ettpy reciffo 1st lassc



ACTIVITY THREE

Identify the Rank Insignia of the Royal Canadian Army Cadets:

Unscramble then match the Rank Insignia.

porcoral _____

feich rranwat fifocer _____

geansert _____

vipraet _____

tanrraw riffocer _____

sterma loporac _____

samreat narawrt cefifor _____



3) List the army cadet ranks in order from lowest to highest rank.

ACTIVITY FOUR

1. Identify the Camps available to you when you complete Level 2. Circle the correct answers.

Intro to Aviation

Aircrew Survival

PERT

Rifle Coach

Into to Leadership

Air Traffic Control

Basic

Technical Training

Music

2. Interview another cadet who has been to a 3 week camp with the following questions.

1. What camp did you attend?
2. Where did you go?
3. What did you eat?
4. How early did you wake up?
5. What fun activities did you partake in?
6. How did you get to camp?
7. Who taught your lessons?
8. What did you do in your free time?
9. What was your favorite thing to do at camp?
10. Did you meet someone from a different province? If so, which one?
11. What was your most memorable moment at camp?

3. Circle the items you can take to camp with you.

- | | |
|--------------------|-----------------------------------|
| a) fake id | l) camera |
| b) cadet boots | m) lock (with key or combination) |
| c) money | n) polish |
| d) lawn mower | o) toothbrush |
| e) alcohol | p) X-box |
| f) soap on a rope | q) Hangers |
| g) shampoo | r) TV |
| h) pornography | s) your dog |
| i) cd player | t) toque |
| j) winter jacket | u) lighters |
| k) combat clothing | v) paper and pens |

ACTIVITY FIVE

Ask your training officer to play the Aviation Trivia Game with you! You must get three answers right to complete this PO.

**PO 404
Citizenship**

GETTING STARTED

Read chapter 3 in the level 2 Handbook, sections 1 to 4. It is a good idea to read the chapter once as an introduction to the material and then a second time to better absorb the information.

ACTIVITY ONE

1. Match the type of government to its description:

AUTOCRACY

Country governed by the people who elect Members to run the country

OLIGARCHY

One person governs, also called dictatorship or absolute monarchy

DEMOCRACY

A small group governs the people

2. Charter of Rights and Freedoms

Select the Rights or Freedoms which ARE NOT in our charter:

- a. Freedom of Speech
- b. Right to Bear Arms
- c. Freedom of the Press
- d. Right of Equality
- e. Right to Impose Justice
- f. Freedom of Religion

3. Government Structure

For each of the following items, place an F for a Federal or P for a Provincial responsibility:

- | | |
|---------------------|-----------------------|
| _____ Education | _____ Foreign Policy |
| _____ Citizenship | _____ Health Care |
| _____ Child Welfare | _____ Currency |
| _____ Highways | _____ Postal Services |

4. Each of the following groups belongs to one of the Branches of the Federal Government. Identify the correct placement of each group by placing it under the correct Branch.

- Prime Minister
- RCMP
- Cabinet
- House of Commons
- Supreme Court
- Senate

Executive

Legislative

Judicial

ACTIVITY TWO

Environmental Preservation

Listed below are some of the words, or practices, we commonly use to help save our environment. Fill the following words into the correct space in the crossword.

Bags

Cans

Cardboard

Conservation

Environment

Garbage

Glass

Litter

Paper

Plastic

Pollution

Recycle

Reduce

Respect

Reuse

Trees

Water

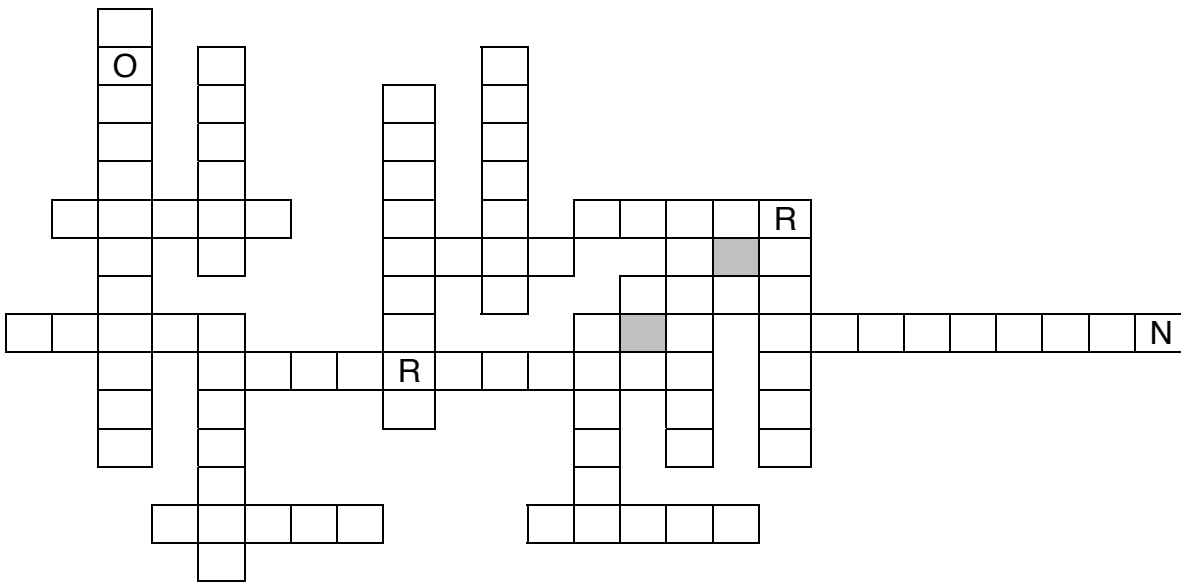

PO 408
LEADERSHIP

GETTING STARTED

Read chapter 6 in the level 2 Handbook, sections 1 and 2. It is a good idea to read the chapter once as an introduction to the material and then a second time to better absorb the information.

ACTIVITY ONE

Discuss the 10 principles of Leadership.

1. What does “lead by setting a good personal example” mean to you?

2. Why is it important to know your cadets and look after their welfare?

3. How does your Squadron Commander develop qualities of leadership in your squadron.

4. Outside of cadets, on what occasions do you need to make sound and timely decisions?

5. What are the benefits to working as a team?

6. Give an example of when it's important to communicate your ideas and thoughts clearly.

7. Why is it important to keep cadets informed of all events? What upcoming events have you been informed of?

8. What is a personal initiative? And what happens if you do not take initiative when the need arises?

9. As a leader why is it important to know your strengths and weaknesses?

10. Why should a leader treat others as they would like to be treated?

ACTIVITY TWO

Discuss the qualities of a Leader.

1. It is not very easy to be a leader. It takes hard work, determination and practice. NCOs work very closely with cadets and should have the best understanding of the way they behave. To lead cadets effectively you must have their respect. As a leader there are certain qualities you must possess if you are to earn the respect of the cadets you lead. List the 10 qualities of a leader and explain the 5 most meaningful to you.

2. What are four qualities that people mistakenly believe leaders must have?
IE: Toughness.



ACTIVITY THREE

The Oxford Dictionary defines confidence as “ Firm trust; assured expectation; boldness”

Discuss the role of confidence in leadership.

1. Confidence is essential. List the five things that a leader must have confidence in.

2. Of these which is the most important and why?

ACTIVITY FOUR

Discuss the duties and responsibilities of a junior NCO.

1. List the three "F's" of leadership and explain each.

2. How should you approach your senior cadets?

It takes hard work to become a good leader and it will not happen overnight. The rewards are great when you know that the cadets respect you and you can get the job done.

TAKE YOUR OWN PHOTOGRAPH

(What kind of leader are you?)

	YES	NO	SOME WHAT
1. Are you good at developing your own level of efficiency? Do you relax as you work –			
a. by changing pace?			
b. by planning, organizing your work?			
c. by talking out your problems?			
d. by doing things for others?			
e. by laughing at yourself; with others?			
2. Do you know how much sleep you need, and assure yourself adequate rest?			
3. Are you able to increase your capacity for work –			
a. by shifting between tasks?			
b. by being strongly motivated?			
c. by associating with more efficient people?			
d. by taking on more responsibility within your recognized limits?			
4. Are you coasting on the job?			
5. Do you exercise sound judgement?			
6. Are you bored?			

Figure 6-1 Take Your Own Photograph

LEADERSHIP TRAITS CHECK-LIST

	YES	NO	FAIRLY
Willing to accept responsibility			
Unselfish			
Cheerful			
Loyal			
Know my job			
Self-confident			
Understanding			
Patient			
In good health			
Honest			
Dependable			
Work hard at the task			
Able to concentrate attention			

Check this list only on the basis of the way in which devote yourself to your leadership responsibility. **DO NOT** mark it on the basis of your general attitude toward life. If all are "yes" re-evaluate.

Figure 6-2 Leadership Traits Check-list

STEPS TOWARD ACHIEVING LEADERSHIP

	NO	...	SELDOM	...	NEVER
1. Stimulate people to want to do the job.	()	...	()	...	()
2. Study subordinates – how they tick.	()	...	()	...	()
3. Practise good listening.	()	...	()	...	()
4. Use constructive criticism.	()	...	()	...	()
5. Criticize privately.	()	...	()	...	()
6. Praise publicly.	()	...	()	...	()
7. Show consideration for others.	()	...	()	...	()
8. Delegate responsibility to other.	()	...	()	...	()
9. Give credit where it is due.	()	...	()	...	()
10. Avoid a domineering attitude.	()	...	()	...	()
11. Be interested in and appreciative of others	()	...	()	...	()
12. Direct by suggestion rather than by orders.	()	...	()	...	()
13. Explain your requests.	()	...	()	...	()
14. Share plans early with subordinates.	()	...	()	...	()
15. Practise standards set for others.	()	...	()	...	()
16. Accent the positive.	()	...	()	...	()
17. Be consistent.	()	...	()	...	()
18. Have confidence in people.	()	...	()	...	()
19. Counsel with subordinates.	()	...	()	...	()
20. Admit your mistakes.	()	...	()	...	()
21. Explain when other's ideas are refused .	()	...	()	...	()
22. Be aware that people see things their own way.	()	...	()	...	()
23. Evaluate what you say before saying it.	()	...	()	...	()
24. Accept moderate complaining (griping) .	()	...	()	...	()
25. Be able to tell others their importance.	()	...	()	...	()
26. Be able to offer subordinates a goal.	()	...	()	...	()
27. Efficiently communicate ideas to others.	()	...	()	...	()

Figure 6-3 (Sheet 2 of 2) Steps Towards Achieving Leadership

PO 410

EFFECTIVE SPEAKING

GETTING STARTED

Read chapter 7 in the level 2 Handbook. It is a good idea to read the chapter once as an introduction to the material and then a second time to better absorb the information.

ACTIVITY ONE

1. Why is a good attitude important when giving a speech?

2. In your experience outside of cadets, when have you been called upon to give an impromptu speech?

ACTIVITY TWO

1. Identify which of the following items are included in the guidelines for delivering an impromptu speech? Please circle the correct answers.

Saying the first thing that comes to mind

Using reasoning and imagination

Chewing bubble gum to calm your nerves

Grasping first thought

Carrying something to comfort you

Logically compiling the introduction, main ideas and body

Pace back and forth

Delivering an effective conclusion

Continuing the speech when you have nothing to say

Speaking clearly and displaying proper dress and deportment

2. There are eight steps to preparing a speech. Match the following definitions with their step. **There are more on the next page!!**

_____ Select and limit the subject

_____ Determine the purpose of the speech

_____ Analyze your audience

_____ Gather data

_____ Outline your material

A. Your speech must have a purpose

B. List the main points that you feel are necessary to accomplish your purpose

C. These are used to hold the attention of your audience

D. When doing this consider the needs and interests of your audience

E. Find out who will be in the audience and what they might already know about your topic.

_____ Organize and develop your speech

F. This must be done to your material so your audience clearly understands it (Introduction, Body, Conclusion).

_____ Plan your visual aids

G. You can do this in front of your friends, family or a mirror.

_____ Practice out loud

H. The basic function of this shows basic thought relationships.

ACTIVITY THREE

1. There are 5 characteristics of the human voice. Please provide an explanation for the following:

1. TONE

2. RANGE

3. PITCH

4. VOLUME

5. INFLECTION

ACTIVITY FOUR

List three things to overcome stage fright

1. _____

2. _____

3. _____

ACTIVITY FIVE

Be prepared to give a one minute and three minute speech. The topics will be given by your training officer

PRINCIPLES OF FLIGHT

GETTING STARTED

Read chapter 8 in the level 2 Handbook, Sections 1 and 2. It is a good idea to read the chapter once as an introduction to the material and then a second time to better absorb the information.

ACTIVITY ONE

1. Label and describe the four forces acting on an aircraft in flight
(Write the force next to the end of each arrow)

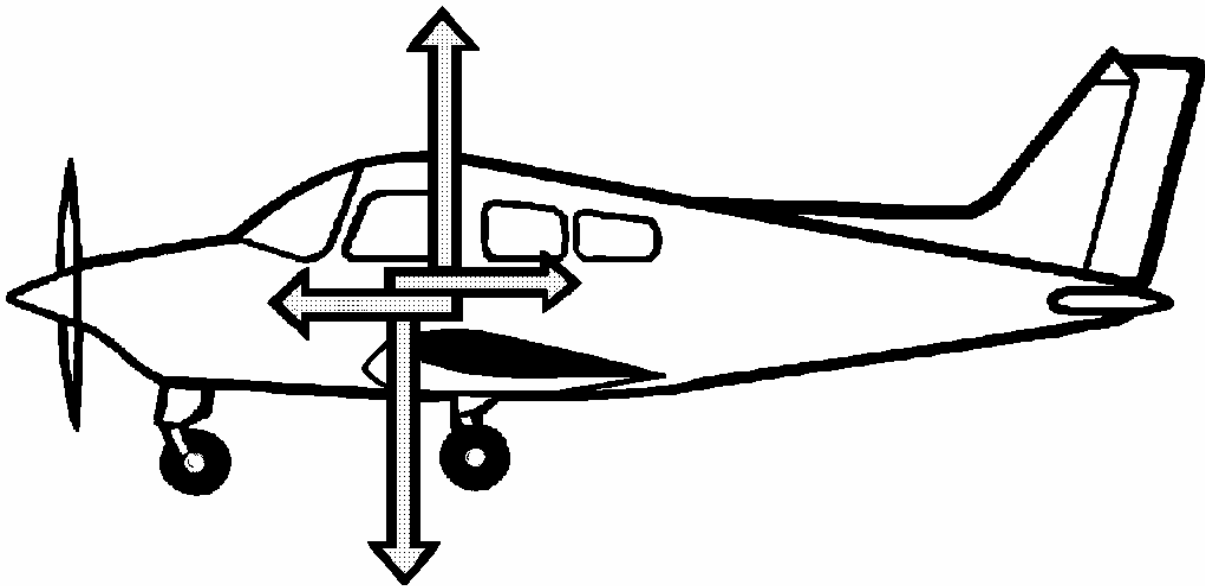

Describe each of the four forces

1. _____

2. _____

3. _____

4. _____

ACTIVITY TWO

The Production of Lift

1. Required materials:

- a. 1 narrow sheet of paper
- b. 1 pencil

2. Make a wing with a sheet of paper by rolling it around a smooth stick or pencil as shown.

3. Blow hard over the top and watch the paper rise as a result of lift being created.

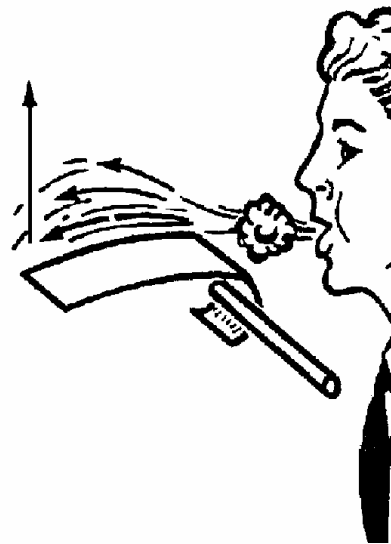

What you have witnessed is called Bernoulli's principle. The energy of the air is constant, so on one side, if the pressure rises, the other side tries to balance the pressure by lowering. So with this experiment, as you blow over the top of the paper, you create a low pressure on top of the paper. The still air underneath the paper has a high pressure. The high pressure pushes upwards to balance the low pressure on top. This causes the paper to rise!

4. Using your knowledge of Bernoulli's Principle Circle the correct statement that describes the movement of air above the wing:

Faster & Lower Pressure

Faster & Higher Pressure

Slower & Lower Pressure

Slower & Higher Pressure



5. Using your knowledge of Bernoulli's Principle Circle the correct statement that describes the movement of air below the wing:

Faster & Lower Pressure

Faster & Higher Pressure

Slower & Lower Pressure

Slower & Higher Pressure

6. Describe the production of lift:

ACTIVITY THREE

Types of Drag

1. Drag is the force that _____
2. All drag created by parts of the aircraft that contribute to lift is called _____
3. Form drag and skin friction are the 2 different types of _____ drag.

ACTIVITY FOUR

Aircraft Axis

1. All aircraft movement takes place around the _____

2. Describe where the following axes are on an aircraft:

a. Longitudinal Axis _____

b. Lateral Axis _____

c. Vertical Axis _____

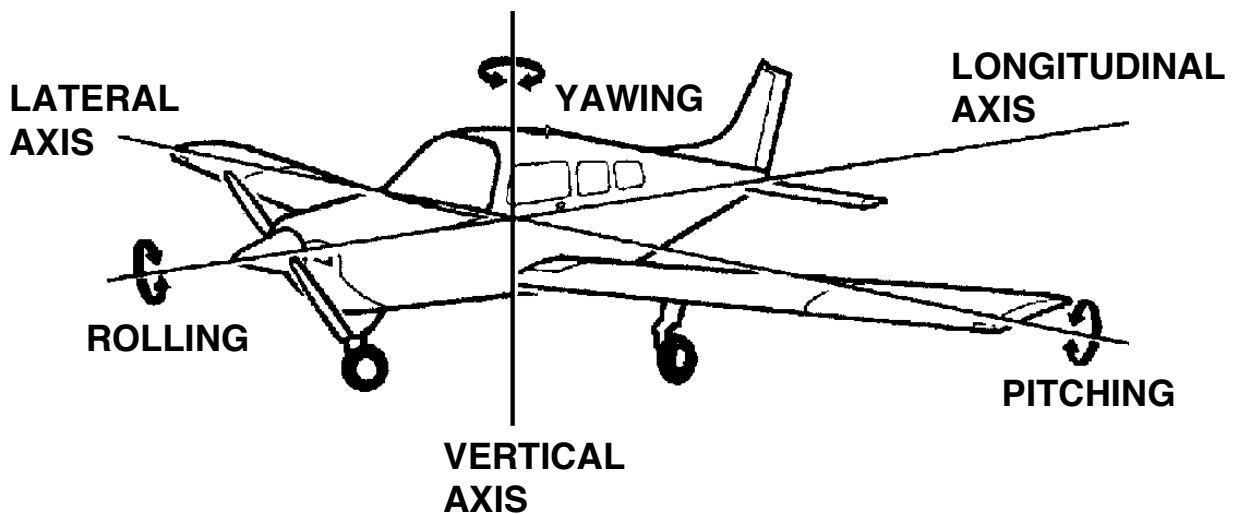

3. Aircraft Control Surfaces

In the spaces provided, identify the movement, the control surface and the axis that causes it.

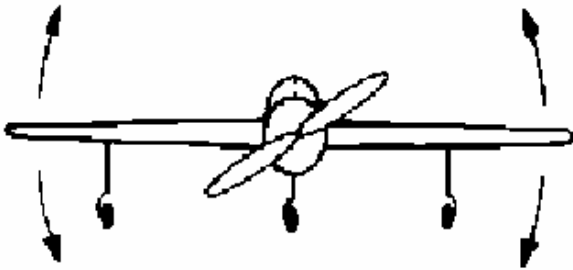

Movement: _____

Control Surface: _____

Axis: _____

Movement:

Control Surface: _____

Axis: _____

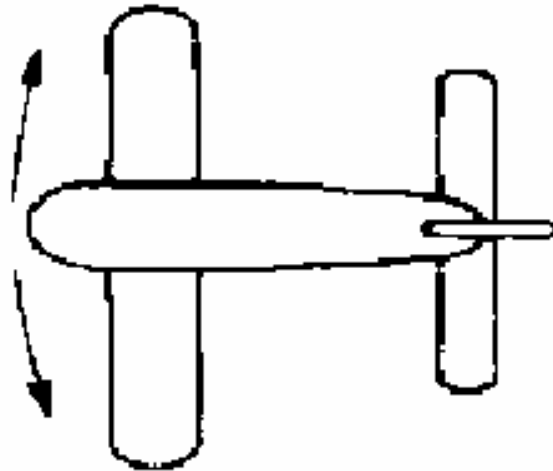

Movement: _____

Control Surface: _____

Axis: _____



Movement: _____

Control Surface: _____

Axis: _____

ACTIVITY FIVE

Match the following aeronautical terms to their definition:

- | | |
|-----------------------|--|
| 1. Airspeed | a. The speed of the aircraft in relation to a point on the ground |
| 2. Stabilizer | b. A surface designed to produce an aerodynamic reaction to its direction of motion |
| 3. Camber | c. An imaginary line from the leading edge to the trailing edge of an airfoil. |
| 4. Groundspeed | d. Measurement from wing tip to wing tip through the center of gravity. |
| 5. Turbulence | e. The balance point. The point through which weight acts downward. |
| 6. Angle of Attack | f. Disturbed air flow. |
| 7. Span | g. The curvature of the wing. |
| 8. Chord | h. Speed of the aircraft in relation to the surrounding air. |
| 9. Airfoil | i. The angle between the relative air flow and the chord of the airfoil. |
| 10. Centre of Gravity | j. Any surface of airfoil shape whose primary function is to correct instability of an aircraft in flight. |

PO 416

Propulsion

GETTING STARTED

Read Chapter 9 in the Level 2 handbook. It is a good idea to read the chapter once as an introduction to the material and then a second time to better absorb the information.

ACTIVITY ONE – Major Engine Types

1. Identify each engine type.

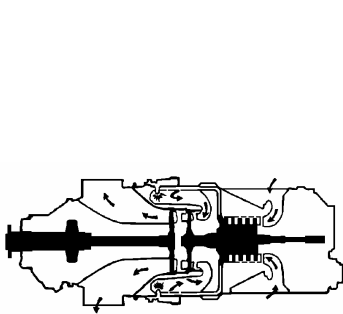

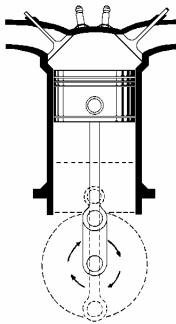

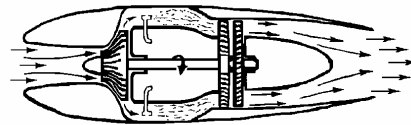

ACTIVITY TWO – Answer the following questions.

1. Give an example of which engine type could have a propeller attached: _____.

2. Give an example of an aircraft which would have:

a) Internal Combustion _____

b) Jet _____

c) Turbo Prop _____

ACTIVITY THREE – Internal Combustion Engine

Fill in the parts of the internal combustion engine in the correct space

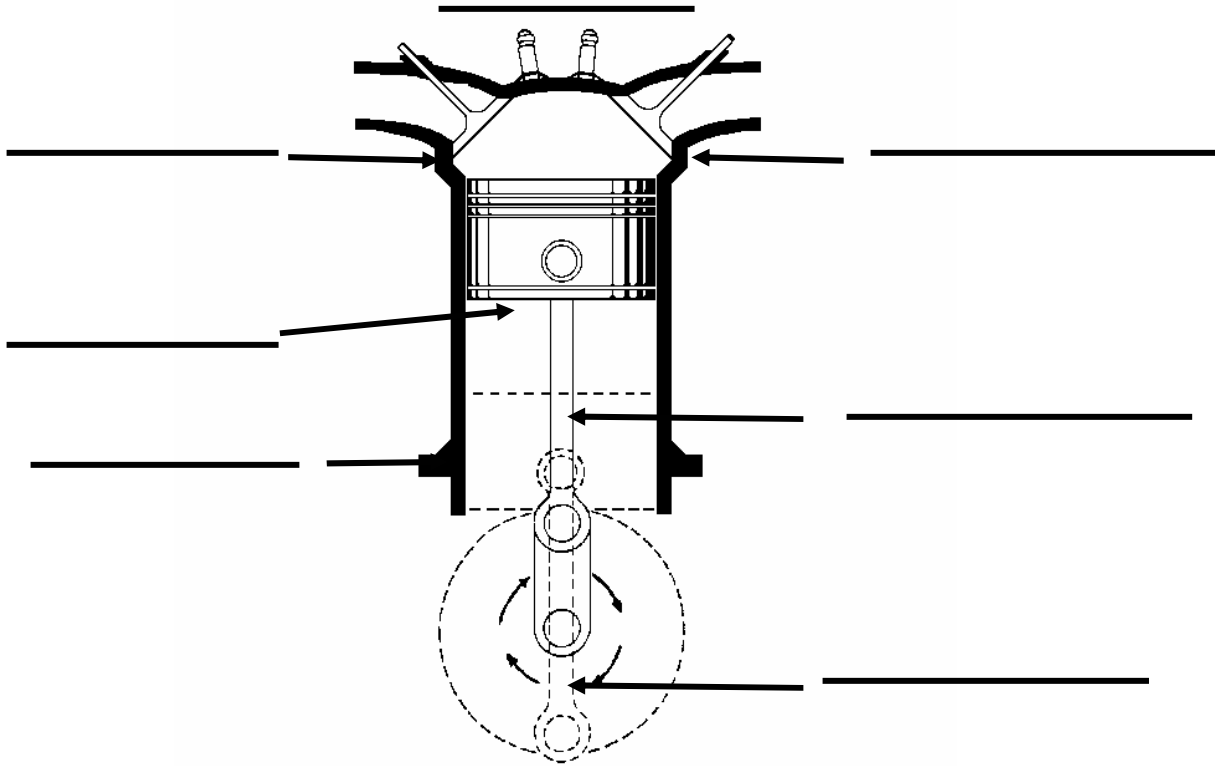

ACTIVITY 4 – Different Types of Internal Combustion Engines.

From the list below, identify the three different types of internal combustion engines.

In-Line

Horizontally Opposed

Radial

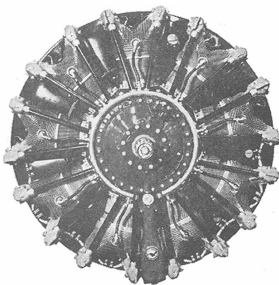

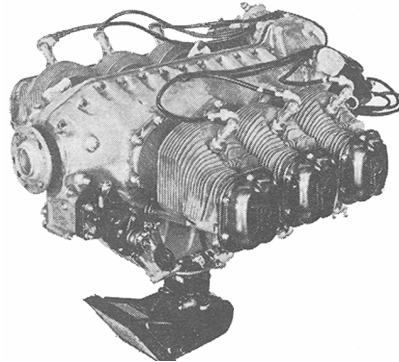

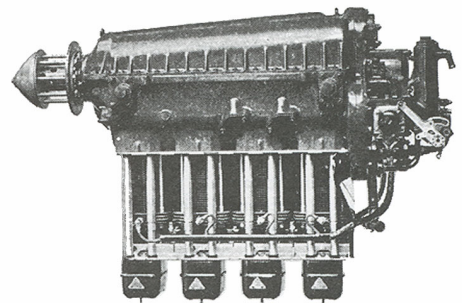

ACTIVITY 5 – The Four Strokes of the Four Stroke Internal Combustion Engine.

Identify each stroke of the four stroke engine.

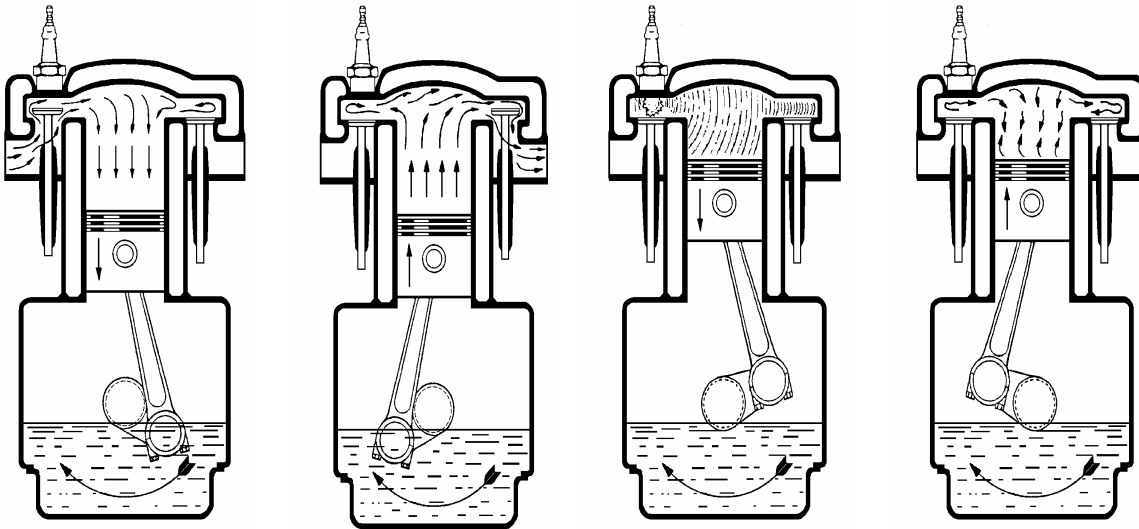

ACTIVITY 6 – Answer the following questions about the Four Stroke Internal Combustion Engine.

1. What is the purpose of the Intake Stroke?

2. During the intake stroke: (refer to previous diagram)

is the intake valve open or closed? _____

is the exhaust valve open or closed? _____

what direction does the piston move (up or down) _____

3. During the compression stroke: (refer to previous diagram)

is the intake valve open or closed? _____

is the exhaust valve open or closed? _____

what direction does the piston move (up or down) _____

4. During the power stroke: (refer to previous diagram)

is the intake valve open or closed? _____

is the exhaust valve open or closed? _____

what direction does the piston move (up or down) _____

5. During the exhaust stroke: (refer to previous diagram)

is the intake valve open or closed? _____

is the exhaust valve open or closed? _____

what direction does the piston move (up or down) _____

6. List the four functions of oil in an internal combustion engine:

1. _____ 2. _____

3. _____ 4. _____

7. Would you find an internal combustion engine in the following: (true/false)

Washing machine: _____

Automobile: _____

Boeing 747: _____

Lawn mower: _____

Television: _____

Cessna 172: _____

Glider: _____

PO 418

RADIO COMMUNICATIONS

GETTING STARTED

Read chapter 10 in the level 2 Handbook. It is a good idea to read the chapter once as an introduction to the material and then a second time to better absorb the information.

ACTIVITY ONE

1. How are radios useful to cadets? Give 3 reasons.

2. What is the purpose of the phonetic alphabet?

3. Numbers are spoken:

- a. all together i.e. 580 = five hundred and eighty
- b. as single digits i.e. 580 = five eight zero
- c. spelled out phonetically i.e. 5 = foxtrot India victor echo ...
- d. as single digits except with whole thousands i.e. 35 000 = three five thousand

1. Give the phonetic alphabet equivalent to the following:

A-
I-
R-

C-
A-
D-
E-
T-
S-

F-
L-
Y-

H-
I-
G-
H-

PO 419

AIRCREW SURVIVAL

GETTING STARTED

Read Chapter 11 of the Level 2 Handbook, Sections 1 to 3. It is a good idea to read it through once as an introduction to the material, and then read it a second time to better absorb the material.

ACTIVITY ONE

1. Draw yourself standing beside bush lean-to intended to shelter yourself only. Label the important parts.

2. List three kinds of natural shelters:
- a.
 - b.
 - c.
3. When placing the boughs on a lean-to you would place them in the same way as shingles on a house.

True

False

ACTIVITY TWO

1. Please circle which type(s) of shoes are suitable for hiking.

Flip-flops

Rubber boots

high cut running shoes

Low cut running Shoes

Fuzzy slippers

sandals

Hiking boots

combat boots

snowshoes

2. When walking uphill, how much of your foot should come in contact with the ground?
3. Circle all that apply when walking downhill.
- a. Run
 - b. Take large paces.
 - c. Take small paces.
 - d. Make sure your whole foot touches the ground.
 - e. Do not lock your knees.

ACTIVITY THREE

1. Describe what important points you would look for to identify a rabbit runway.

2. How large of the loop for your rabbit snare be?

- a. the size of your head.
- b. the size of a peanut.
- c. the size of your fist.

3. The bottom of the loop for a rabbit snare should be _____ inches/centimeters above the ground.

4. List three other sources of food and how you would get them.

a. _____

b. _____

c. _____

