



National  
Defence

Défense  
nationale

A-CR-CCP-913/PW-001



# Canadian Cadet Organizations

## Pipe Band – Snare Drum Reference Manual



### Chapter 2

## Snare Drum – Level Two

# Chapter 2 – Table of Contents

	Tempo (BPM)	Page
<b>Section 1 Technique Exercises</b>		
Single Strokes	120	2-1-1
Double Strokes	96	2-1-2
Flams	96	2-1-3
Drags	96	2-1-4
Paradiddles	96	2-1-5
Quick March Attack Rolls	96	2-1-6
Slow March Attack Rolls	48	2-1-7
<b>Section 2 Repertoire</b>		
Mairi's Wedding	96	2-2-1
The Green Hills of Tyrol – Elementary	96	2-2-2
When the Battle's O'er – Elementary	96	2-2-3
Scotland The Brave – Elementary	96	2-2-4
The Bluebells of Scotland	96	2-2-5
The Nut Brown Maiden	96	2-2-6
Will Ye No Come Back Again – Elementary	96	2-2-7
The Quaker's Wife – Elementary	96	2-2-8
The Steamboat	96	2-2-9
The Skye Boat Song – Elementary	48	2-2-10
Going Home – Elementary	48	2-2-11
Scotland the Brave (Advance in Review Order)	96	2-2-12
The Maple Leaf Forever (General Salute)	96	2-2-12

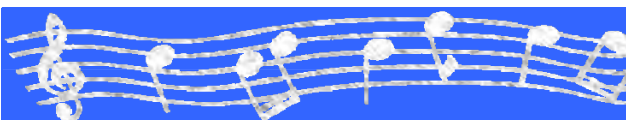

**C  
H  
A  
P  
T  
E  
R  
  
2**

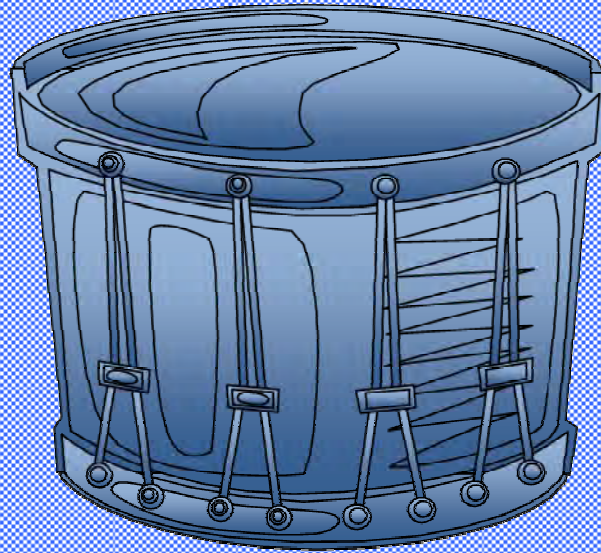



***Section 1***

**Technique Exercises**





# Single Strokes

1  $\frac{2}{4}$  

2  $\frac{2}{4}$  

3  $\frac{2}{4}$  

4  $\frac{2}{4}$  

5  $\frac{2}{4}$  

6  $\frac{6}{8}$  

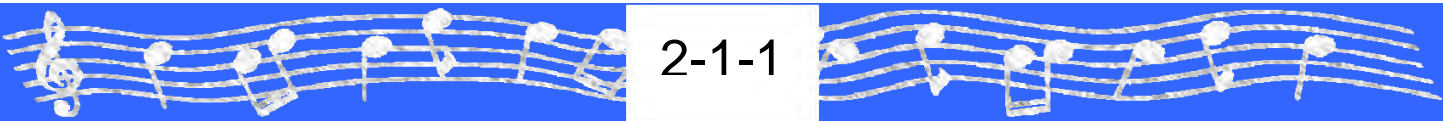

# Double Strokes

7  $\frac{2}{4}$

8  $\frac{2}{4}$

9  $\frac{2}{4}$

10  $\frac{2}{4}$

11  $\frac{2}{4}$

12  $\frac{2}{4}$

13  $\frac{2}{4}$

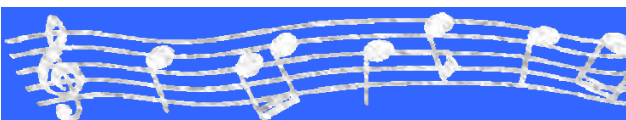

2-1-2



# Flams

14  $\frac{2}{4}$  

15  $\frac{4}{4}$  

16  $\frac{2}{4}$  

17  $\frac{2}{4}$  

18  $\frac{2}{4}$  

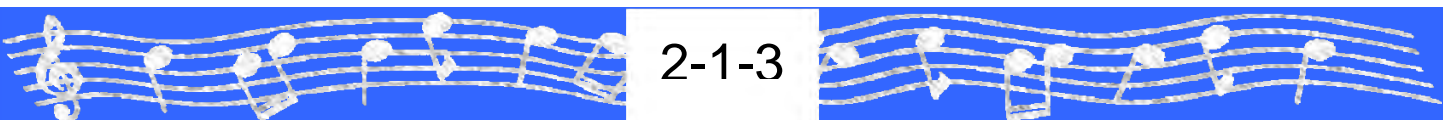

# Drags



- A drag is an embellishment similar to a flam.
- **Right Drag:** A buzz on the right hand followed by a main stroke on the left hand.
- **Left Drag:** A buzz on the left hand followed by a main stroke on the right hand.

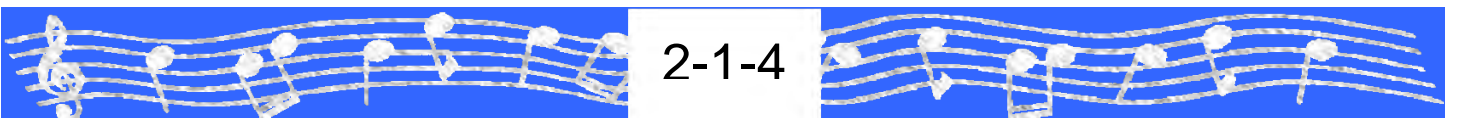

# Paradiddles

21  $\frac{2}{4}$

22

23

24

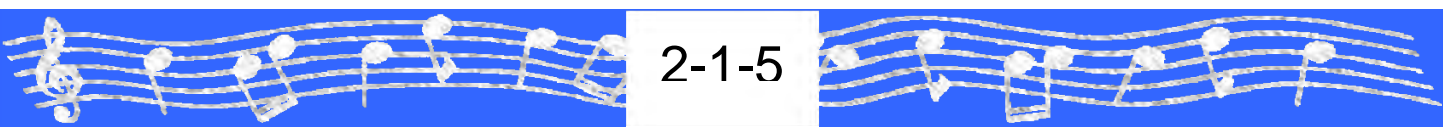



# Attack Rolls

## 25 Quick March Attack

The musical score is written for four parts: Tenor Drum, Bass Drum, Snare Drum, and Bagpipes, all in 4/4 time. It is divided into three sections by vertical lines:

- Word of Command:** The Tenor Drum part has the text "Rolls.....Quick March" below it. All parts play a series of rhythmic strokes.
- Rolls:** The Tenor Drum part has three circled 'X' marks above it. The Bagpipes part has the instruction "Hand up to Bag" above it. The Tenor Drum part has the text "Drones.....'E'" below it.
- Start of Tune:** The Tenor Drum part has two circled 'X' marks above it. The Bagpipes part begins with a melodic line.

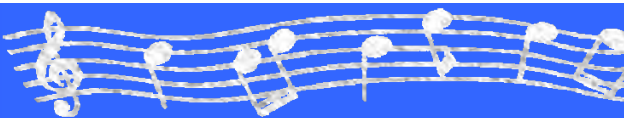

2-1-6



# Attack Rolls

## 26 Slow March Attack

The musical score is divided into three sections: **Word of Command**, **Rolls**, and **Start of Tune**.

**Word of Command:** The Tenor Drum, Bass Drum, and Snare Drum play a rhythmic pattern of quarter notes. The Bagpipes play a single note with the instruction "Hand up to Bag".

**Rolls:** The Tenor Drum plays three notes marked with a circled 'X'. The Bass Drum plays three notes. The Snare Drum plays three notes with a slur. The Bagpipes play three notes with the instruction "Drones.....'E'".

**Start of Tune:** The Tenor Drum and Bass Drum play two notes marked with a circled 'X'. The Snare Drum plays a sequence of notes with a slur. The Bagpipes play a sequence of notes with a slur.

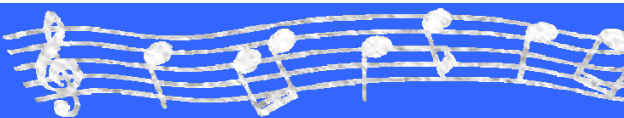

2-1-7



**C  
H  
A  
P  
T  
E  
R  
  
2**

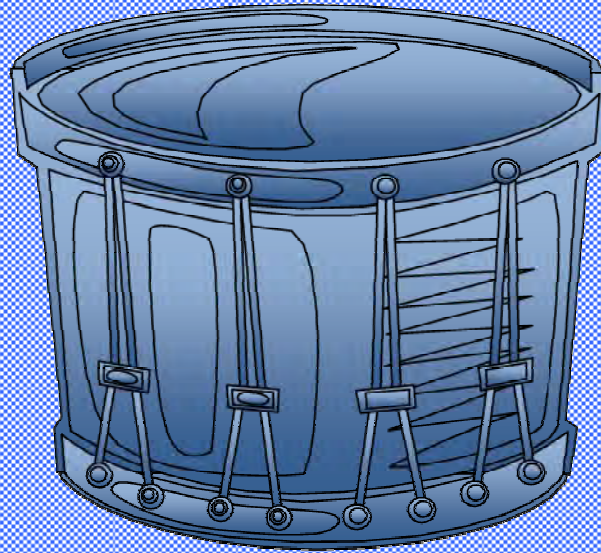

# *Section 2*

## Repertoire



# Mairi's Wedding

March

The musical score for 'Mairi's Wedding' is written in 2/4 time. It consists of four staves. The first staff begins with a treble clef, a 2/4 time signature, and a key signature of one flat (B-flat). The melody is characterized by eighth-note patterns and quarter notes, with several measures containing beamed eighth notes. The second and fourth staves end with double bar lines and repeat dots. The third staff begins with a bass clef and a repeat sign.

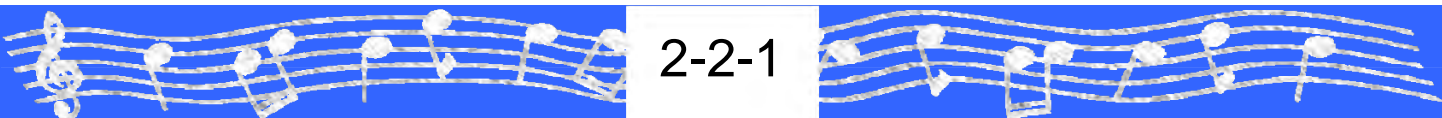

# The Green Hills of Tyrol

Retreat March  
Elementary

The musical score is written on four staves in treble clef with a 3/4 time signature. The first staff begins with a repeat sign. The melody consists of eighth and quarter notes, often beamed together. There are two triplet markings (indicated by a '3' above a bracket) in the second and third measures of the first staff, and the second and third measures of the second staff. The piece concludes with a double bar line and repeat dots.

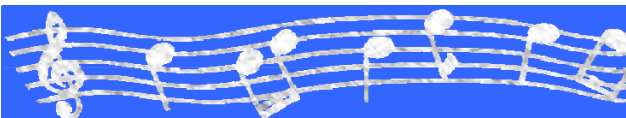

2-2-2



# When The Battle's O'er

Retreat March  
Elementary

Musical score for 'Retreat March' in 3/4 time, elementary level. The score consists of four staves of music. The first staff begins with a treble clef, a 3/4 time signature, and a repeat sign. The melody features eighth and sixteenth notes, with a triplet of eighth notes in the second measure. The second staff continues the melody with a triplet of eighth notes in the second measure and ends with a double bar line. The third and fourth staves repeat the first two staves, with the fourth staff ending with a double bar line. The key signature is one flat (B-flat).



2-2-3



# Scotland The Brave

March  
Elementary

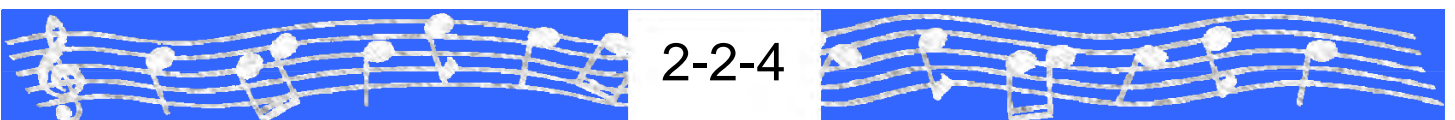

# The Bluebells of Scotland

March

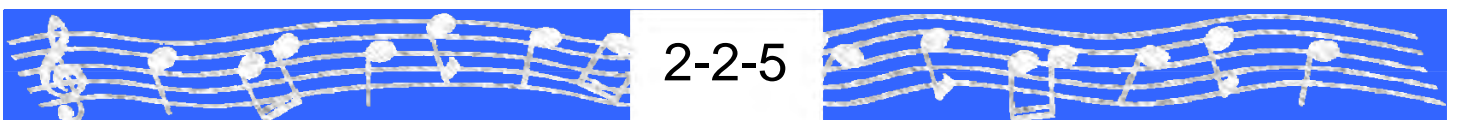



# The Nut Brown Maiden

March

The image displays a musical score for a march titled "The Nut Brown Maiden". The score is written on two staves. The top staff begins with a treble clef, a 4/4 time signature, and a key signature of one sharp (F#). The melody consists of a series of eighth and sixteenth notes, with some notes beamed together. The bottom staff provides a bass line accompaniment, primarily using quarter and eighth notes. Both staves conclude with a double bar line and repeat dots, indicating the end of the piece.

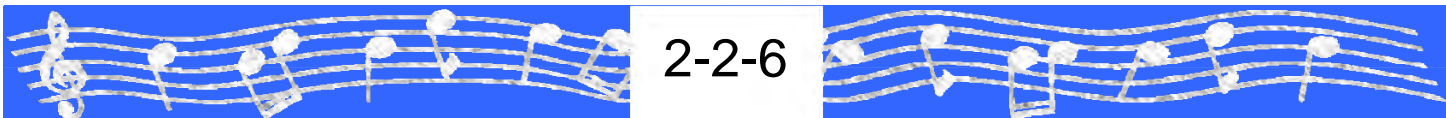

# Will Ye No Come Back Again

March  
Elementary

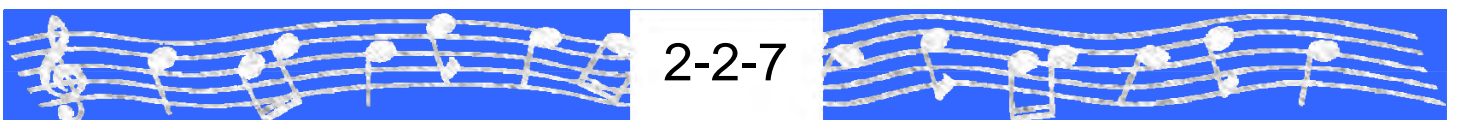

# The Quaker's Wife

March  
Elementary

The musical score is written for a single melodic line in 6/8 time. It begins with a treble clef and a key signature of one flat (B-flat). The piece consists of 16 measures, divided into two 8-measure phrases. The first phrase starts with a repeat sign. The melody is characterized by eighth-note patterns and rests. A triplet of eighth notes appears in the 7th measure of both phrases. The piece concludes with a double bar line and repeat dots.

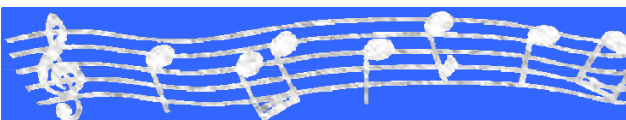

2-2-8



# The Steamboat

March

Musical score for 'The Steamboat' march, consisting of four staves of music. The first staff begins with a treble clef, a 2/4 time signature, and a key signature of one flat (B-flat). The melody is written on a single staff with a treble clef. The music features a series of eighth and sixteenth notes, often beamed together, and includes several measures with slurs. The piece concludes with a double bar line and repeat dots. The second and fourth staves are identical to the first, while the third staff is a variation of the first two.

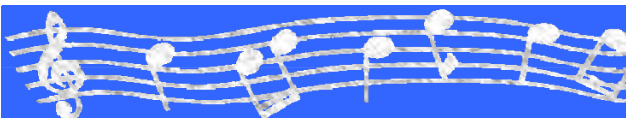

2-2-9



# The Skye Boat Song

Slow March  
Elementary

The musical score for 'The Skye Boat Song' is presented in four staves. The first staff begins with a treble clef, a 6/8 time signature, and a key signature of one flat (B-flat). The melody consists of eighth and quarter notes, with several measures featuring slurs. The second staff continues the melody with similar note values and slurs. The third staff introduces a bass clef and features a more rhythmic pattern with eighth notes and rests. The fourth staff continues this bass line, ending with a double bar line and repeat dots.

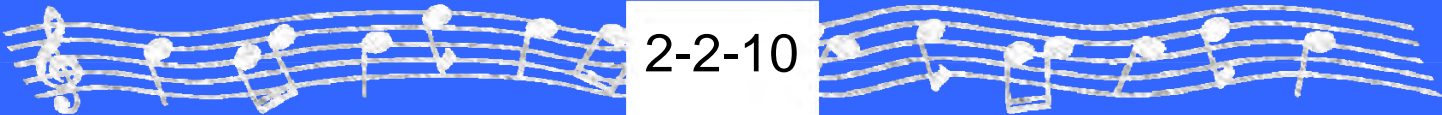

# Going Home

Slow March  
Elementary

The musical score for 'Going Home' is presented in four staves. The first staff begins with a treble clef, a 6/8 time signature, and a key signature of one flat (B-flat). The melody consists of eighth and quarter notes, with some notes beamed together. The second staff continues the melody and ends with a double bar line and repeat dots. The third staff shows the bass line, featuring a series of chords and single notes, with two slanted lines indicating dynamics. The fourth staff continues the bass line and also ends with a double bar line and repeat dots.

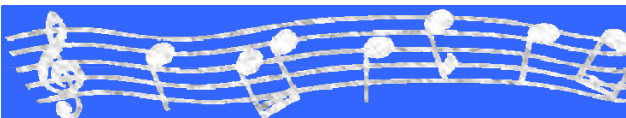

2-2-11



# The Advance and General Salute

Advance

Scotland The Brave

Arr: Maj A.M. Cairns MMM CD

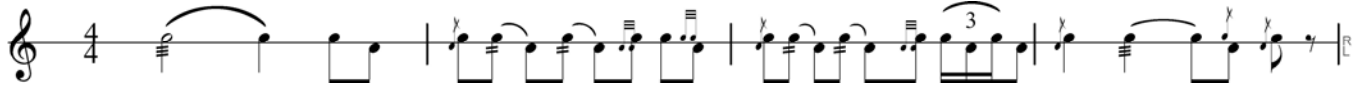

General Salute

The Maple Leaf Forever

Arr: Maj A.M. Cairns MMM CD

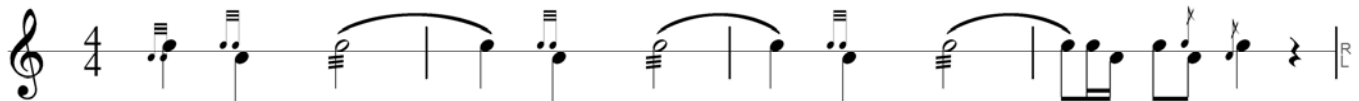

There are three salutes used within the Canadian Forces and Canadian Cadet Organization, the Royal Salute\*, the Royal (Vice-Regal) Salute\*\* and the General Salute. The following table illustrates the use of these salutes based on the status of the dignitary being honoured.

\*Note: The Royal Salute is covered in Level 4. \*\*Note: The Royal (Vice-Regal) Salute is covered in Level 3.

## Royal Salute (Mallorca)

- HM the Queen
- Members of the Royal Family
- Foreign Sovereigns
- Members of Reining Foreign Families
- Heads of State
- Governor General of Commonwealth Countries.

## Royal (Vice-Regal) Salute (Mallorca / O' Canada)

- Governor General of Canada
- Lieutenant Governor of a Canadian Province

## General Salute (Maple Leaf Forever)

- Prime Minister of Canada
- Premiers of Canadian Provinces
- Members of Parliament (provincial or federal)
- Municipal Politicians
- Military Officers (major and above)
- Distinguished Persons



2-2-12

