



National  
Defence

Defense  
nationale

A-CR-CCP-911/PW-003



# Canadian Cadet Organizations

## Pipe Band – Bass Drum and Tenor Drum

### Reference Manual

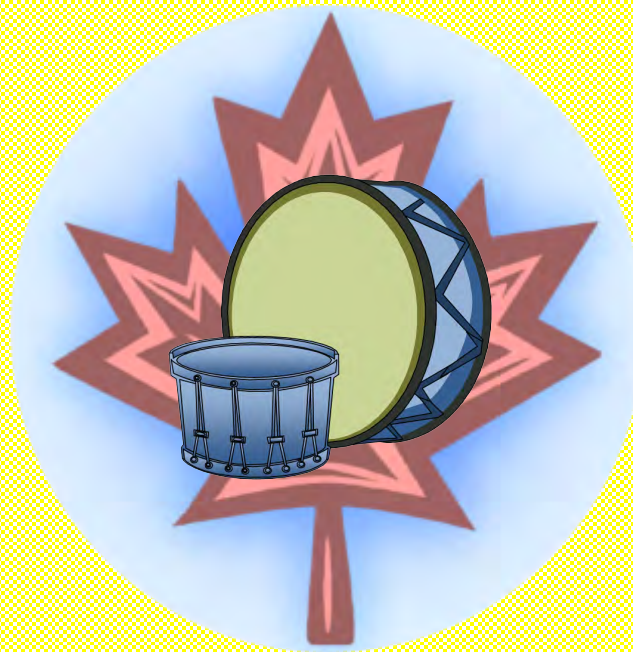

## Chapter 4

### Bass Drum and Tenor Drum – Level Four



Canada

# Chapter 4 – Table of Contents

	Tempo (BPM)	Page
<b>Section 1 Technique Exercises</b>		
Flourishing Symbol Chart	N/A	4-1-1
Flip Flourishes	96	4-1-2
Reverse Flourishes	96	4-1-3
Flourish Combinations and Transitions	96	4-1-4
<b>Section 2 Repertoire</b>		
2/4 Quick March Bass Drum Beating	96	4-2-1
2/4 Quick March Flourishing Routine	96	4-2-2
2/4 Slow March Bass Drum Beating	60	4-2-5
2/4 Slow March Flourishing Routine	60	4-2-6
4/4 Quick March Bass Drum Beating	96	4-2-7
4/4 Quick March Flourishing Routine	96	4-2-8
3/4 Retreat March Bass Drum Beating	96	4-2-10
3/4 Retreat March Flourishing Routine	96	4-2-11
Pipe Major J.K. Carins Bass Drum Beating	96	4-2-13
Pipe Major J.K. Carins Flourishing Routine	96	4-2-14
6/8 Quick March Bass Drum Beating	96	4-2-16
6/8 Quick March Flourishing Routine	96	4-2-17
6/8 Slow March Bass Drum Beating	60	4-2-20
6/8 Slow March Flourishing Routine	60	4-2-21
9/8 Retreat March Bass Drum Beating	96	4-2-22
9/8 Retreat March Flourishing Routine	96	4-2-23
Jig Bass Drum Beating	120	4-2-24
Jig Flourishing Routine	120	4-2-25
Strathspey Bass Drum Beating	132	4-2-26
Strathspey Flourishing Routine	132	4-2-27
Reel Bass Drum Beating	120	4-2-28
Reel Flourishing Routine	120	4-2-29
Hornpipe Bass Drum Beating	108	4-2-31
Hornpipe Flourishing Routine	108	4-2-32
Royal Salute (Vice-Regal) and Royal Salute Bass Drum Beating	48	4-2-33
Royal Salute (Vice-Regal) and Royal Salute Flourishing Routine	48	4-2-34

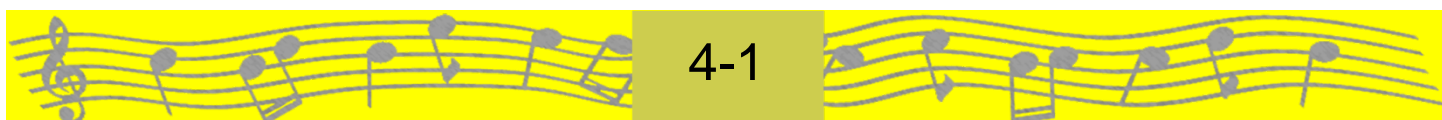

C  
H  
A  
P  
T  
E  
R  
  
4











# *Section 1*

## Technique Exercises

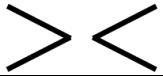

# Flourishing Symbol Chart

## Level 4

Flourish	Symbol
Figure Eight Flourish	
Reverse Figure Eight Flourish	
Monkey Flip Flourish	
Outside Flip Flourish (Left)	
Outside Flip Flourish (Right)	
Double Outside Flip Flourish	
Reverse Butterfly Flourish	
Reverse Crossed Arm Stall Flourish	
Reverse Single Flourish	
Reverse Double Flourish	

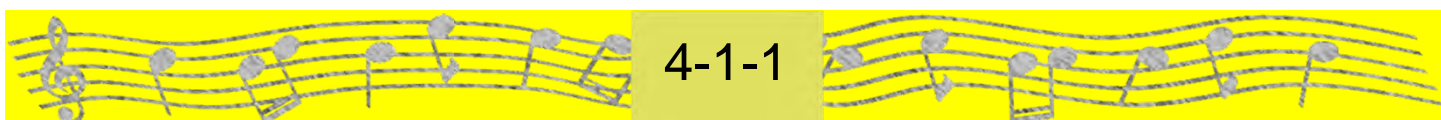

# Flip Flourishes

**1**

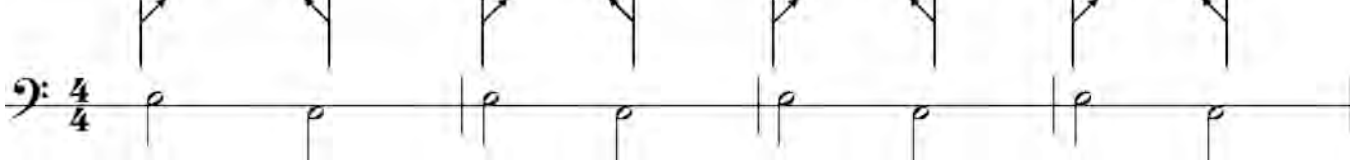

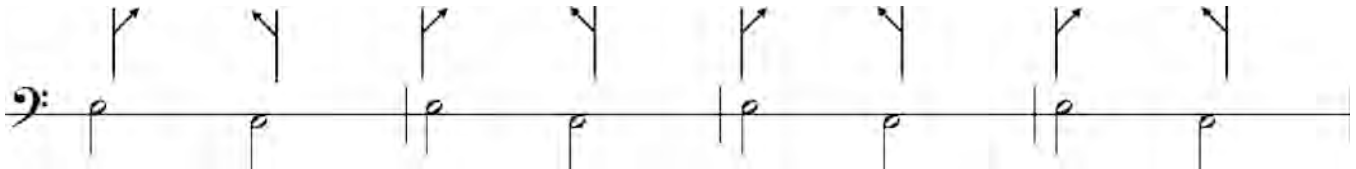

**2**

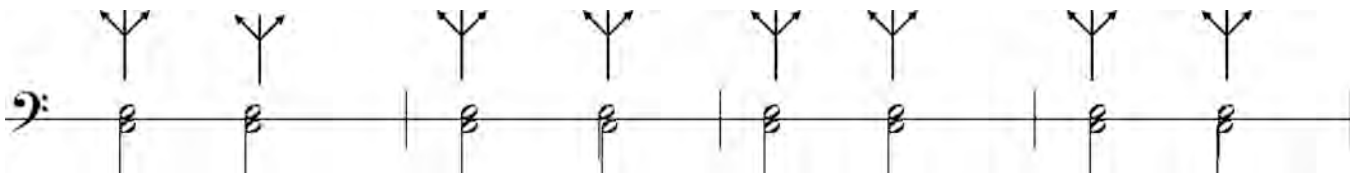

**3**



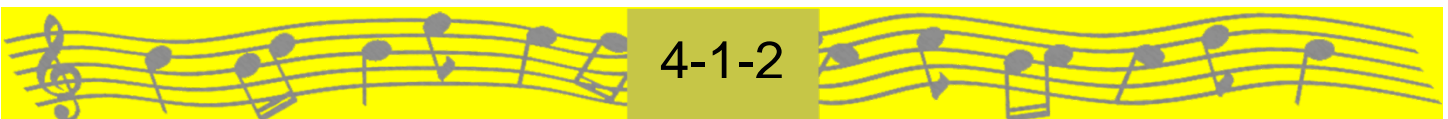

**4**



4-1-2

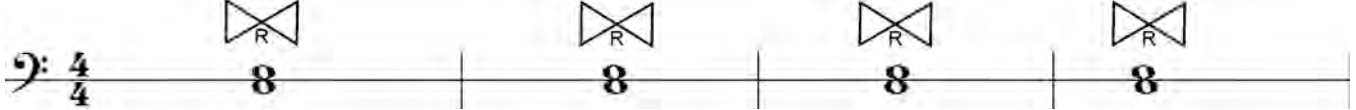

# Reverse Flourishes

**5** 

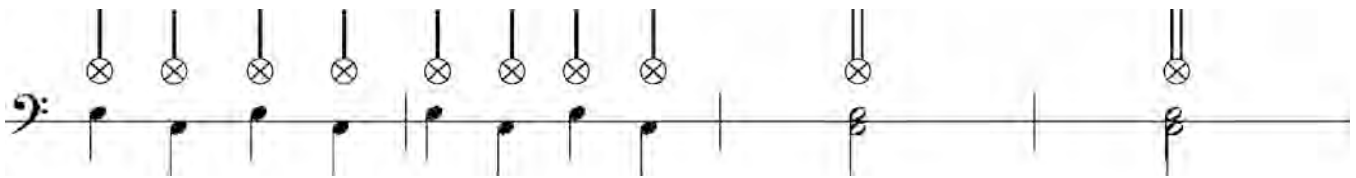
**6** 

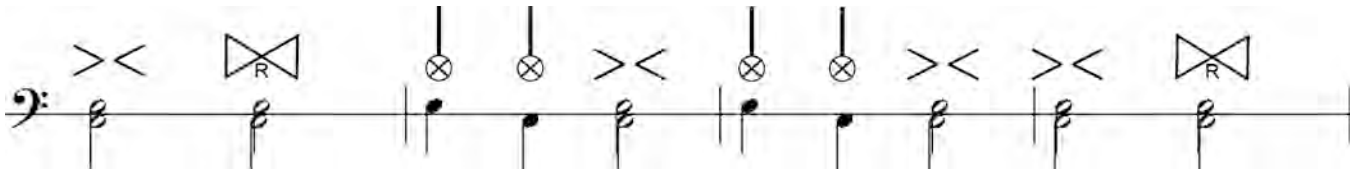
**7** 

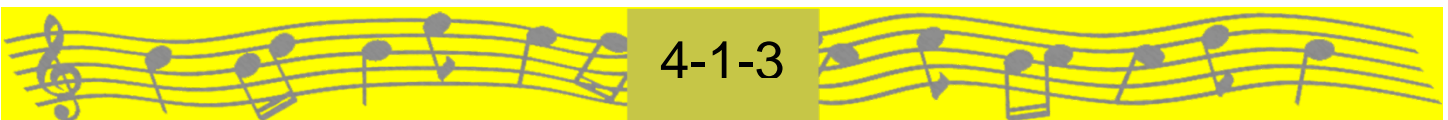
**8** 

 4-1-3 

# Flourish Combinations and Transitions

9

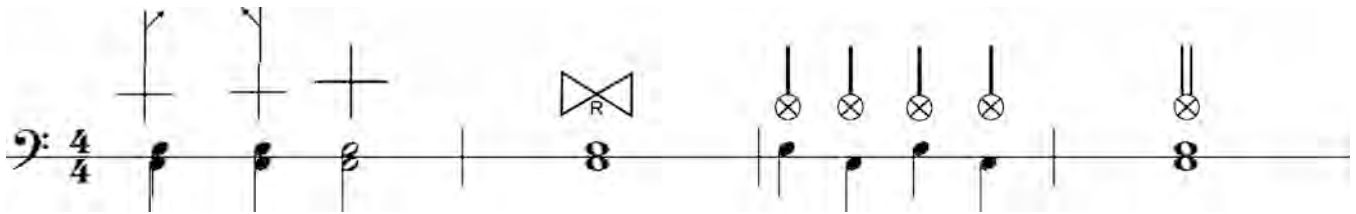

10

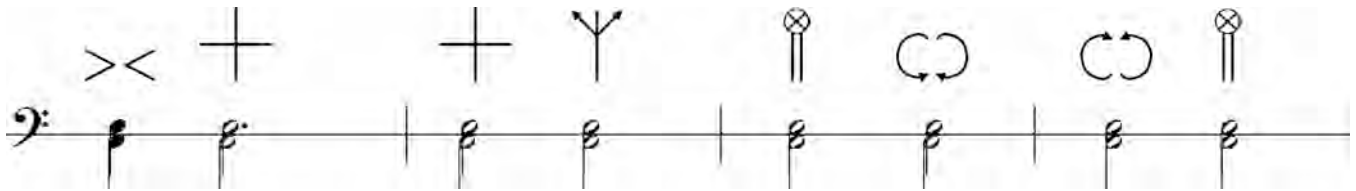

11

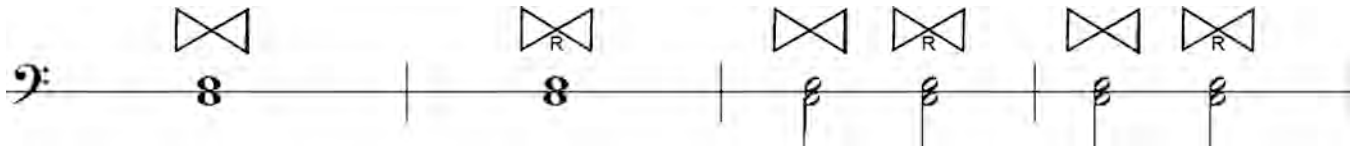

12

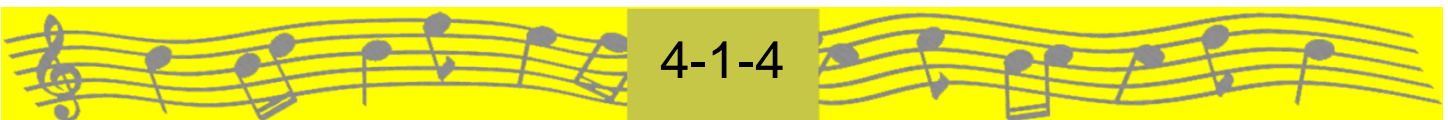
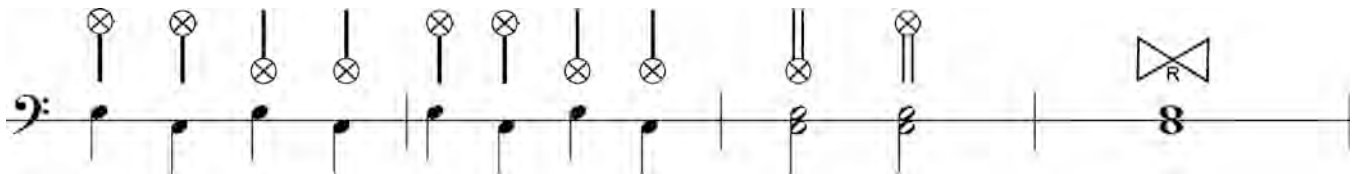





C  
H  
A  
P  
T  
E  
R  
  
4

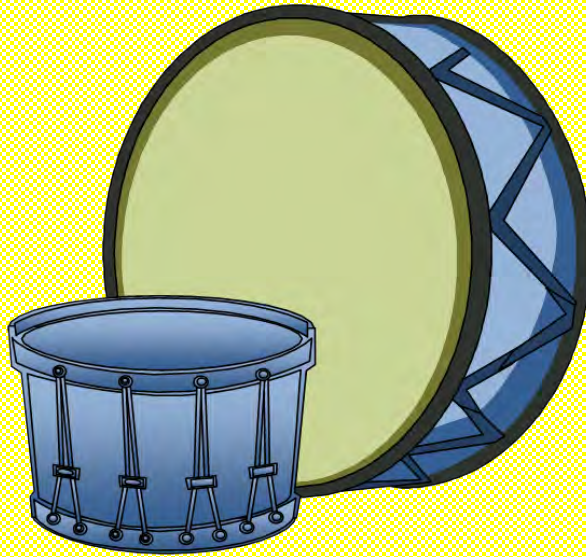

# *Section 2*

## Repertoire



# 2/4 Quick March Bass Drum Beating

March

Four staves of musical notation for bass drum beating in 2/4 time. The notation uses a bass clef and a 2/4 time signature. The first staff begins with a double bar line and a repeat sign. The notes are:  $\text{G}_2$  (quarter),  $\text{A}_2$  (quarter),  $\text{G}_2$  (quarter),  $\text{F}_2$  (quarter),  $\text{E}_2$  (quarter),  $\text{D}_2$  (quarter),  $\text{C}_2$  (quarter),  $\text{B}_1$  (quarter). The second staff continues:  $\text{A}_2$  (quarter),  $\text{G}_2$  (quarter),  $\text{F}_2$  (quarter),  $\text{E}_2$  (quarter),  $\text{D}_2$  (quarter),  $\text{C}_2$  (quarter),  $\text{B}_1$  (quarter),  $\text{A}_2$  (quarter). The third staff continues:  $\text{G}_2$  (quarter),  $\text{F}_2$  (quarter),  $\text{E}_2$  (quarter),  $\text{D}_2$  (quarter),  $\text{C}_2$  (quarter),  $\text{B}_1$  (quarter),  $\text{A}_2$  (quarter),  $\text{G}_2$  (quarter). The fourth staff concludes:  $\text{F}_2$  (quarter),  $\text{E}_2$  (quarter),  $\text{D}_2$  (quarter),  $\text{C}_2$  (quarter),  $\text{B}_1$  (quarter),  $\text{A}_2$  (quarter),  $\text{G}_2$  (quarter),  $\text{F}_2$  (quarter). All notes have an accent (>) above them. The piece ends with a double bar line.

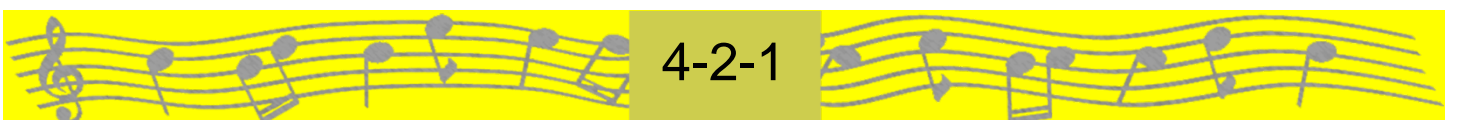

# 2/4 Quick March Flourishing Routine

March

The musical score is written for six staves in bass clef, 2/4 time. The first staff begins with a double bar line and a key signature of one flat. The notation includes eighth notes, quarter notes, and rests, with various ornaments such as slurs, trills, and grace notes. The second staff continues the melody with similar rhythmic patterns and ornaments. The third staff features a series of quarter notes with trills, followed by a half note with a trill and a quarter rest. The fourth staff contains a series of quarter notes with trills, a half note with a trill, and a quarter note with a trill. The fifth staff continues the melody with eighth notes and quarter notes, and the sixth staff concludes the routine with a final flourish.

*(Continued on next page)*

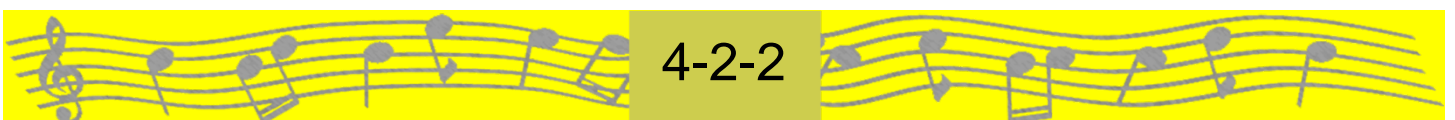

# 2/4 Quick March Flourishing Routine

*(Continued)*

The image displays six staves of musical notation for a 2/4 Quick March Flourishing Routine. Each staff begins with a bass clef. The notation includes various rhythmic and melodic elements:

- Staff 1:** Features a sequence of quarter notes with stems pointing down, each marked with a circled 'X'. The notes are on the G, F, E, and D lines of the bass clef. The final measure contains a whole note chord consisting of G and D.
- Staff 2:** Starts with quarter notes on G and F. The third measure has a slur over a pair of eighth notes (G and F) with a 'M' flourish above. The fourth measure has a slur over a pair of eighth notes (E and D) with another 'M' flourish. The fifth measure has a quarter note on G with a solid black circle above it. The sixth measure has a quarter note on F with a circled 'X' above it.
- Staff 3:** Consists of eighth notes beamed in pairs, moving from G-F to E-D. Each pair is marked with a double-headed zigzag flourish above.
- Staff 4:** Similar to Staff 3, but the final measure is a whole note chord (G and D) marked with a circled 'X' above.
- Staff 5:** Features quarter notes on G and F, with a '7' (flourish) above the G in the fifth measure. The notes are marked with double-headed zigzag flourishes above.
- Staff 6:** Similar to Staff 5, but the final measure has a solid black circle above the G and a circled 'X' above the F.

*(Continued on next page)*

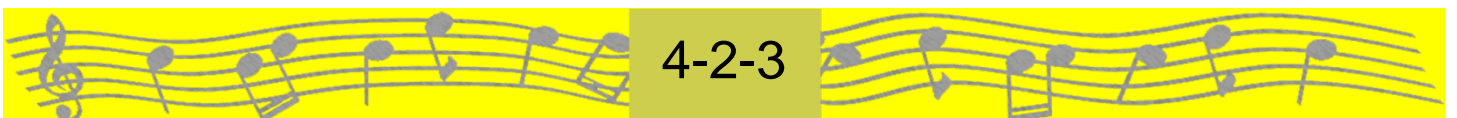

# 2/4 Quick March Flourishing Routine

(Continued)

The image displays four staves of musical notation for a 2/4 Quick March Flourishing Routine. Each staff begins with a bass clef. The notation includes various rhythmic and melodic elements:

- Staff 1:** Four measures of eighth-note pairs (quarter notes) with a double bar line above each pair.
- Staff 2:** Four measures of eighth-note pairs (quarter notes) with a double bar line above each pair, followed by a measure with a circled 'x' above a quarter note, and a measure with a circled '7' above a quarter note.
- Staff 3:** Four measures of quarter notes with a circled 'x' above each note, followed by a measure with a circled 'x' above a quarter note and a circled 'x' above a quarter note, and a measure with a circled 'x' above a quarter note and a circled 'x' above a quarter note.
- Staff 4:** Four measures of quarter notes with a cross above each note, followed by a measure with a circled 'x' above a quarter note and a circled 'x' above a quarter note, and a measure with a circled 'x' above a quarter note and a circled 'x' above a quarter note.

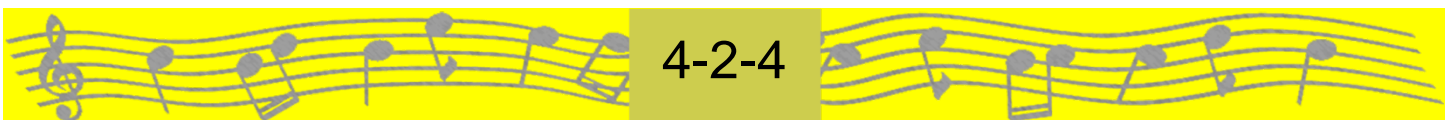

# 2/4 Slow March Bass Drum Beating

Slow March

The image displays five staves of musical notation for a bass drum in 2/4 time, labeled 'Slow March'. The notation is written in bass clef and includes a key signature of one flat (B-flat). The first staff begins with a repeat sign and a first ending bracket. The second staff ends with a repeat sign and a first ending bracket. The third staff begins with a repeat sign and a first ending bracket. The fourth staff is marked with a '1' above the first measure and ends with a repeat sign and a first ending bracket. The fifth staff is marked with a '2' above the first measure and ends with a repeat sign and a first ending bracket. The notation consists of quarter notes and eighth notes, with accents (>) placed above the notes to indicate the drumming pattern.

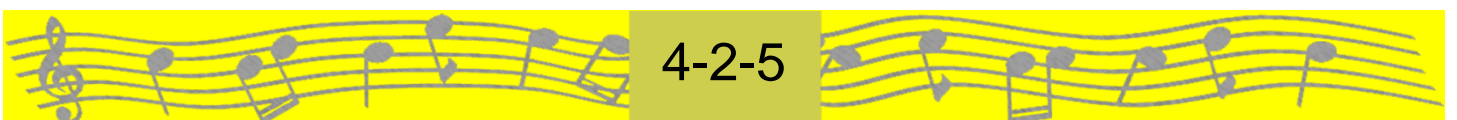

# 2/4 Slow March Flourishing Routine

March

The image displays a musical score for a 2/4 Slow March Flourishing Routine. It consists of five staves, each in bass clef. The first staff is marked with a 2/4 time signature. Above the staves are various musical symbols: circled X's, vertical lines, double lines, and zig-zag patterns. The second and third staves include circular arrows indicating flourishes. The fourth staff features zig-zag patterns above the notes. The fifth staff includes a double line symbol above the notes.

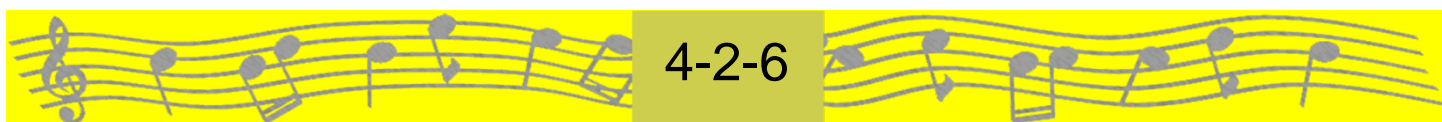

# 4/4 Quick March Bass Drum Beating

March

Three staves of bass drum notation in 4/4 time. The notation includes various rhythmic patterns such as quarter notes, eighth notes, and rests, all marked with an accent (>). The first staff begins with a repeat sign. The second and third staves continue the rhythmic sequence.

4-2-7



# 4/4 Quick March Flourishing Routine

March

The image displays six staves of musical notation for a 4/4 Quick March Flourishing Routine. Each staff begins with a bass clef and a 4/4 time signature. The notation includes various rhythmic symbols such as eighth notes, quarter notes, and rests, along with decorative flourishes like circles, triangles, and crosses. The first staff has a 4/4 time signature. The second staff has a bass clef. The third staff has a bass clef. The fourth staff has a bass clef. The fifth staff has a bass clef. The sixth staff has a bass clef.

*(Continued on next page)*

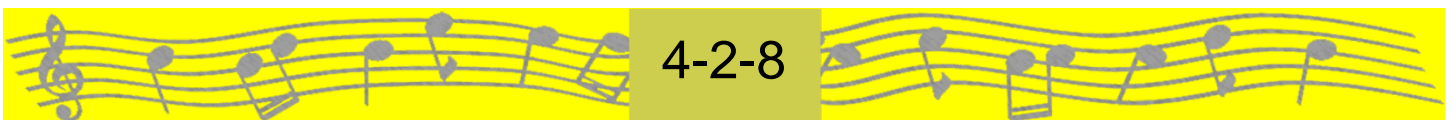

# 4/4 Quick March Flourishing Routine

(Continued)

The image displays two staves of musical notation for a 4/4 Quick March Flourishing Routine. The notation is as follows:

- Staff 1 (Top):** Bass clef. It contains four measures. The first three measures each contain two pairs of eighth notes, each pair marked with a 'C' above it. The fourth measure contains a single eighth note marked with a circled 'X' above it, followed by a quarter rest.
- Staff 2 (Bottom):** Bass clef. It contains four measures. The first four measures each contain a single eighth note marked with a circled 'X' above it. The fifth and sixth measures each contain a pair of eighth notes marked with a 'C' above them. The seventh measure contains a pair of eighth notes marked with a circled 'X' above them. The eighth measure contains a pair of eighth notes marked with a 'C' above them. The final measure contains a pair of eighth notes marked with a circled 'R' above them, followed by a quarter rest and a double bar line.

A decorative footer featuring musical notation on a yellow background. The notation consists of a treble clef, a series of eighth notes, and a double bar line. The number "4-2-9" is centered in a dark grey box between two sections of musical notation.

# 3/4 Retreat March Bass Drum Beating

March

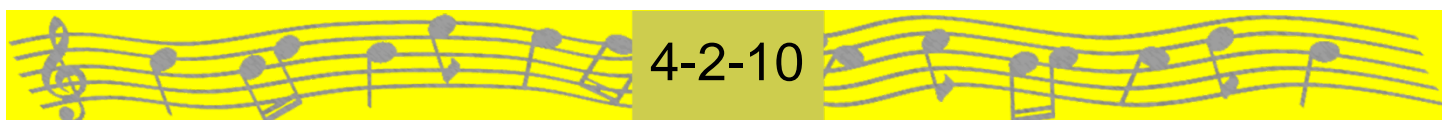

# 3/4 Retreat March Flourishing Routine

March

The image displays a musical score for a 3/4 time signature march, consisting of six staves. The notation includes various rhythmic values such as eighth and sixteenth notes, rests, and beams. It features several musical ornaments: circles with an 'X' inside, circles with two vertical lines, and a triangle with an 'R' inside. Some notes are beamed together and have a slur above them. The score concludes with a double bar line and repeat dots.

*(Continued on next page)*

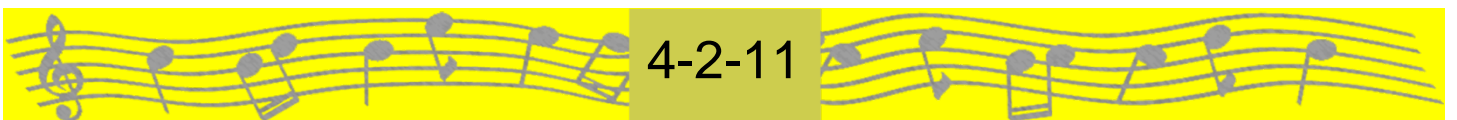

# 3/4 Retreat March Flourishing Routine

(Continued)

Musical notation for a 3/4 Retreat March Flourishing Routine. The notation is presented in two staves, both using a bass clef. The top staff contains a sequence of eighth notes with various ornaments, including horizontal lines and circles with an 'X' inside. The bottom staff contains a sequence of chords and single notes, with various ornaments including a triangle with an 'R' inside, a solid black circle, a circle with an 'X' inside, and a cross.

Decorative footer featuring musical notation on a yellow background. The notation consists of a treble clef, a series of eighth notes, and a central box containing the text "4-2-12".

# Pipe Major J.K. Cairns Bass Drum Beating

March

The image displays four staves of bass drum notation in 3/4 time. The notation consists of quarter notes and eighth notes, all marked with an accent (>). The first staff begins with a repeat sign and contains three measures of eighth-note patterns followed by a quarter note. The second and fourth staves consist of quarter notes. The third staff contains three measures of eighth-note patterns followed by a quarter note. The notation is arranged in a 2x2 grid.

# Pipe Major J.K. Cairns Flourishing Routine

March

The image displays a musical score for a pipe major flourish routine, consisting of six systems of two staves each. The top staff of each system is in bass clef with a 3/4 time signature. The bottom staff of each system contains various pipe major symbols: circles with an 'X' (representing a pipe major flourish), a 'C' in a triangle (representing a cut), a diamond with an 'X' (representing a flourish), a solid black circle (representing a flourish), a vertical line with an 'X' (representing a flourish), a plus sign (representing a flourish), a vertical line with an arrow (representing a flourish), a vertical line with a Y (representing a flourish), and a diamond with an 'R' (representing a flourish). The notation includes eighth and sixteenth notes, rests, and various articulation marks.

*(Continued on next page)*

# Pipe Major J.K. Cairns Flourishing Routine

*(Continued)*

Musical notation for Pipe Major J.K. Cairns Flourishing Routine (Continued). The notation is presented in two staves, both in bass clef. The top staff contains a sequence of eighth notes with various ornaments: a horizontal line with a circled cross, a horizontal line with a circled cross, a horizontal line with a circled cross, a vertical line with a circled cross, a vertical line with a circled cross, and a horizontal line with a circled cross. The bottom staff contains a circled cross with a horizontal line, a circled cross with a horizontal line and a triangle containing the letter 'R' above it, a solid black circle, a circled cross with a vertical line, a greater-than and less-than sign (><), a vertical line with a Y-shape above it, and a cross symbol.

Decorative footer featuring musical notation on a yellow background. The notation consists of a treble clef, a series of eighth notes, and a central box containing the page number 4-2-15.



# 6/8 Quick March Bass Drum Beating

March



# 6/8 Quick March Flourishing Routine

March

The image displays six systems of musical notation for a 6/8 Quick March Flourishing Routine. Each system consists of a single bass clef staff. The notation includes various rhythmic and melodic elements:

- System 1: Starts with a 6/8 time signature. The first two measures contain eighth notes. The third measure has a slur over two eighth notes. The fourth measure has a quarter note. The fifth measure has a slur over two eighth notes. The sixth measure has a quarter note.
- System 2: Similar to System 1, but with a circled '8' above the third measure and a circled '8' above the fourth measure. The sixth measure has a quarter note.
- System 3: Starts with a circled '8' above the first measure. The first two measures contain eighth notes. The third measure has a quarter note. The fourth measure has a quarter note. The fifth measure has a quarter note. The sixth measure has a quarter note.
- System 4: Starts with a circled '8' above the first measure. The first two measures contain eighth notes. The third measure has a quarter note. The fourth measure has a quarter note. The fifth measure has a quarter note. The sixth measure has a quarter note.
- System 5: Starts with a circled '8' above the first measure. The first two measures contain eighth notes. The third measure has a quarter note. The fourth measure has a quarter note. The fifth measure has a quarter note. The sixth measure has a quarter note.
- System 6: Starts with a circled '8' above the first measure. The first two measures contain eighth notes. The third measure has a quarter note. The fourth measure has a quarter note. The fifth measure has a quarter note. The sixth measure has a quarter note.

*(Continued on next page)*

# 6/8 Quick March Flourishing Routine

(Continued)

The image displays six staves of musical notation in bass clef, representing a 6/8 Quick March Flourishing Routine. Each staff contains four measures of music, with various rhythmic and melodic symbols above the notes. The symbols include circles with an 'X' inside, solid black circles, Y-shapes, plus signs, triangles with 'c' inside, and vertical lines with horizontal bars. The notation is organized into six rows, each with four measures. The first row has symbols: X, X, solid circle, solid circle, Y, and plus sign. The second row has: triangle with 'c', inverted triangle with 'c', Y, plus sign, solid circle, and X. The third row has: vertical line with horizontal bar, 8, solid circle, and plus sign. The fourth row has: vertical line with horizontal bar, 8, X, and a note with a slur. The fifth row has: Z, Z, Z, Z, 8, and infinity symbol. The sixth row has: Z, Z, a note with a slur, and a note with a slur and an X.

(Continued on next page)

# 6/8 Quick March Flourishing Routine

(Continued)

The image displays four staves of musical notation, each representing a different instrument part in a 6/8 Quick March Flourishing Routine. The notation is written in bass clef and includes various rhythmic and melodic elements:

- Staff 1:** Features a series of eighth notes with slurs and accents. Above the first two measures are two vertical lines with a horizontal bar, and above the last two measures is a cross symbol.
- Staff 2:** Similar to the first staff, but includes a circled '8' above the second measure and a circled 'X' above the third measure. The final two measures show eighth notes with stems.
- Staff 3:** Includes a circled 'X' above the first measure, a diamond shape with a horizontal bar above the second measure, and a Y-shaped flourish above the third measure. The final two measures have eighth notes with stems.
- Staff 4:** Features a Y-shaped flourish above the first measure, a cross symbol above the second measure, a circular flourish above the third measure, a circled 'X' above the fourth measure, and a solid black circle above the fifth measure. The final two measures have eighth notes with stems.

# 6/8 Slow March Bass Drum Beating

Slow March

Musical notation for Bass Drum Beating in 6/8 time, consisting of four staves. The notation is written in bass clef with a 6/8 time signature. The first staff begins with a repeat sign and a double bar line. The notation includes various rhythmic patterns such as dotted eighth notes, quarter notes, and eighth notes, often beamed together. The second staff ends with a double bar line and repeat dots. The third staff begins with a repeat sign and a double bar line. The fourth staff ends with a double bar line and repeat dots.

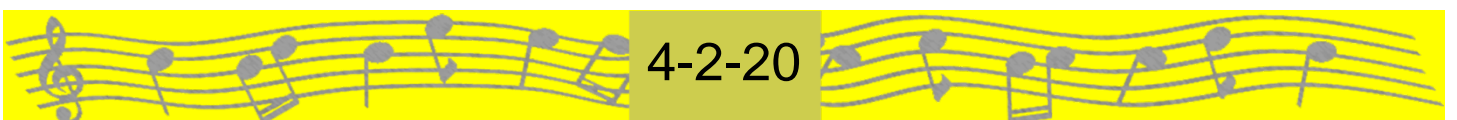

# 6/8 Slow March Flourishing Routine

Slow March

The image shows two staves of musical notation for a 6/8 Slow March Flourishing Routine. The top staff is in bass clef with a 6/8 time signature. It contains eight measures of music, each with a flourish symbol above it. The first two measures have a 'Z' flourish, the next two have a '⊗' flourish, and the last two have a '⊗' flourish. The bottom staff is also in bass clef and contains eight measures of music. The first measure has a '⊗' flourish, the second has a '+' flourish, the third and fourth have '+' flourishes, and the fifth has a 'Λ' flourish. The notes are represented by stems and dots, indicating the pitch and rhythm of the flourishes.

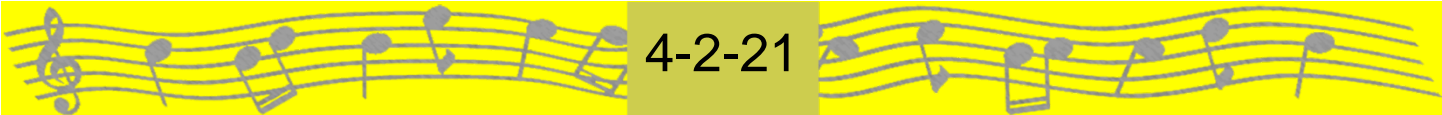

# 9/8 Retreat March Bass Drum Beating

March

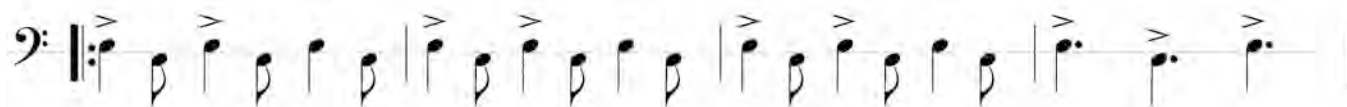

# 9/8 Retreat March Flourishing Routine

March

The musical score is presented in two systems, each with a melody line and a bass line. The melody lines are in bass clef with a 9/8 time signature. The first system's melody consists of eighth notes with accents, followed by dotted eighth notes. The bass line features eighth notes with stems pointing down, some marked with a circled 'X' above them, and some with a circled 'X' below them. The second system's melody is identical to the first. The bass line includes eighth notes with stems pointing down, some marked with a circled 'X' above them, and some with a circled 'X' below them. Additionally, there are zigzag symbols above the bass line in the second system, and a circled 'X' above the final eighth note.



# Jig Bass Drum Beating

Jig

The image displays four staves of musical notation for a jig bass drum beating pattern. The notation is written in bass clef with a 6/8 time signature. Each staff shows a sequence of notes with accents, representing the drumming pattern. The first staff begins with a repeat sign. The second staff ends with a repeat sign. The third and fourth staves also begin with a repeat sign. The notes are primarily quarter notes and half notes, with accents indicating the drumming emphasis.

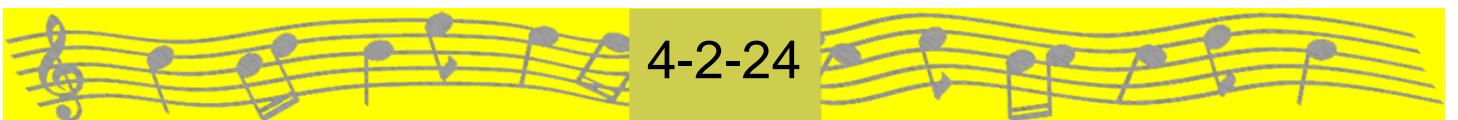

# Jig Flourishing Routine

Jig

Musical notation for a Jig Flourishing Routine in bass clef, 6/8 time. The notation consists of two staves. The top staff shows a sequence of eighth notes with upward stems, grouped in pairs and then in groups of four. The final measure of the top staff features a triplet of eighth notes. The bottom staff shows a sequence of eighth notes with downward stems, grouped in pairs and then in groups of four. The final measure of the bottom staff features a cross symbol above the note.

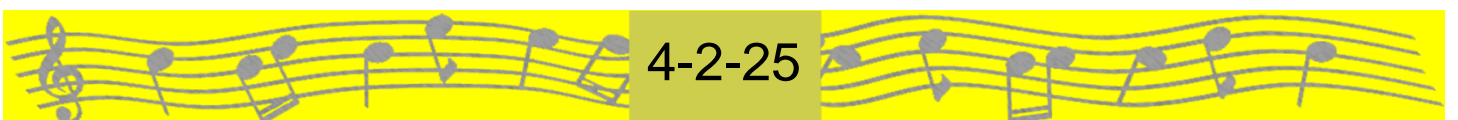

# Strathspey Bass Drum Beating

Strathspey

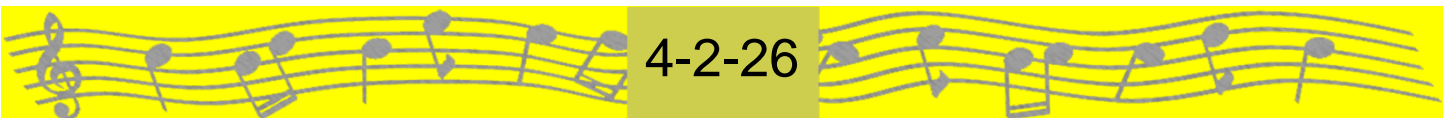

# Strathspey Flourishing Routine

## Strathspey

The image displays four staves of musical notation for a Strathspey Flourishing Routine. The notation is organized into four rows, each representing a staff. The first staff begins with a bass clef and a 4/4 time signature. Above the staff, rhythmic symbols are placed: L, L, ⊗, ⊗, L, L, ⊗, ⊗, L, L, ⊗, ⊗, and ⊘. The staff contains notes and rests corresponding to these symbols. The second staff features a bass clef and a large '8' symbol. Above it are symbols: ⊘, ∞, ⊘, ∞, ⊘, ∞, ⊘, ∞, ∪, ∩, ∇, and ●. The third staff has a bass clef and a large '8' symbol. Above it are symbols: L, L, ⊗, ⊗, L, L, ⊗, ⊗, L, L, ⊗, ⊗, and ⊘. The fourth staff has a bass clef and a large '8' symbol. Above it are symbols: ⊘, ⊘, ⊘, ⊘, ⊘, ⊘, ⊘, and ∇.

# Reel Bass Drum Beating

Reel

Four staves of bass drum notation in common time (C). Each staff begins with a bass clef and a common time signature. The notation consists of quarter notes on a single line, with various accents and dynamic markings. The first staff starts with a repeat sign and a first ending bracket. The second staff ends with a repeat sign and a double bar line. The third and fourth staves also end with a repeat sign and a double bar line.

# Reel Flourishing Routine

Reel

The image displays six staves of musical notation for a Reel Flourishing Routine in 2/2 time. Each staff consists of a series of notes and rests, with various ornaments and flourishes indicated by symbols above or below the notes. The notation includes eighth notes, quarter notes, and rests, with some notes beamed together. The ornaments include diamond shapes, circles with an 'X', and other decorative symbols. The staves are arranged in a 2x3 grid. The first two staves have a treble clef and a 2/2 time signature. The remaining four staves have a bass clef. The notation is as follows:

- Staff 1: Treble clef, 2/2 time. Notes: quarter rest, quarter note, quarter note, quarter note, quarter note. Ornaments: diamond above the first two notes, circles with 'X' above the last four notes.
- Staff 2: Treble clef, 2/2 time. Notes: quarter rest, quarter note, quarter note, quarter note, quarter note. Ornaments: diamond above the first two notes, circles with 'X' above the last four notes.
- Staff 3: Bass clef. Notes: quarter note, quarter note, quarter note, quarter note, quarter note, quarter note. Ornaments: circles with 'X' above the first two notes, circles with 'X' above the next two notes, diamond above the fifth note, circle with 'X' above the sixth note.
- Staff 4: Bass clef. Notes: quarter note, quarter note, quarter note, quarter note, quarter note, quarter note. Ornaments: 'c' above the first four notes, diamond above the fifth note, circle with 'X' above the sixth note.
- Staff 5: Bass clef. Notes: quarter rest, quarter note, quarter note, quarter note, quarter note. Ornaments: diamond above the first two notes, circles with 'X' above the last four notes.
- Staff 6: Bass clef. Notes: quarter rest, quarter note, quarter note, quarter note, quarter note. Ornaments: diamond above the first two notes, circles with 'X' above the last four notes.

*(Continued on Next Page)*

# Reel Flourishing Routine

*(Continued)*

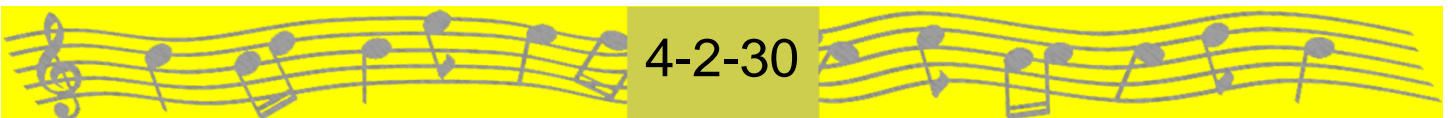

# Hornpipe Bass Drum Beating

Hornpipe

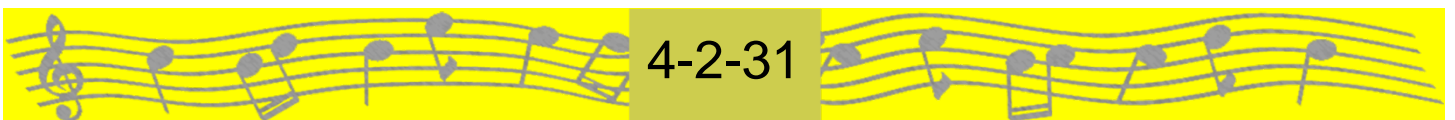
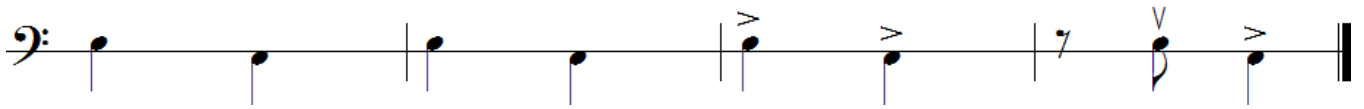
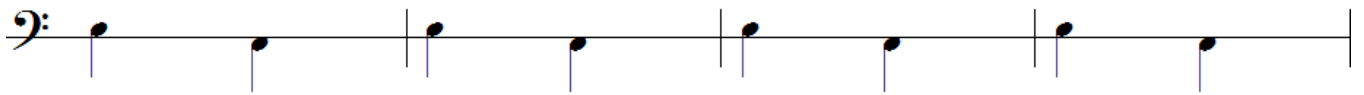
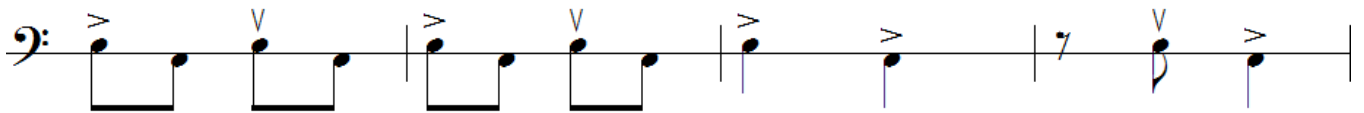
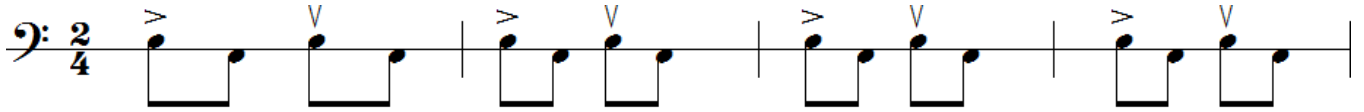



# Hornpipe Flourishing Routine

Hornpipe

Musical notation for Hornpipe Flourishing Routine in bass clef, 2/4 time. The notation consists of two staves. The top staff begins with a bass clef and a 2/4 time signature. It contains three measures of music, each with a slur over two notes and an '8' above the slur. Above the first measure is a Y-shaped flourish symbol. Above the second measure is a Y-shaped flourish symbol with a vertical line extending downwards. Above the third measure is an '8'. The bottom staff begins with a bass clef. It contains four measures of music. The first measure has a Y-shaped flourish symbol above it. The second measure has a slur over two notes and an '8' above the slur. The third measure has a solid black circle above it. The fourth measure has a circled X symbol above it.

Decorative footer featuring musical notation on a yellow background. The notation is in treble clef and consists of a sequence of notes. A central grey box contains the number "4-2-32".

# Vice-Regal and Royal Salute Bass Drum Beating

Royal (Vice-Regal) Salute  
Slow Air / March

*Mallorca / O' Canada*

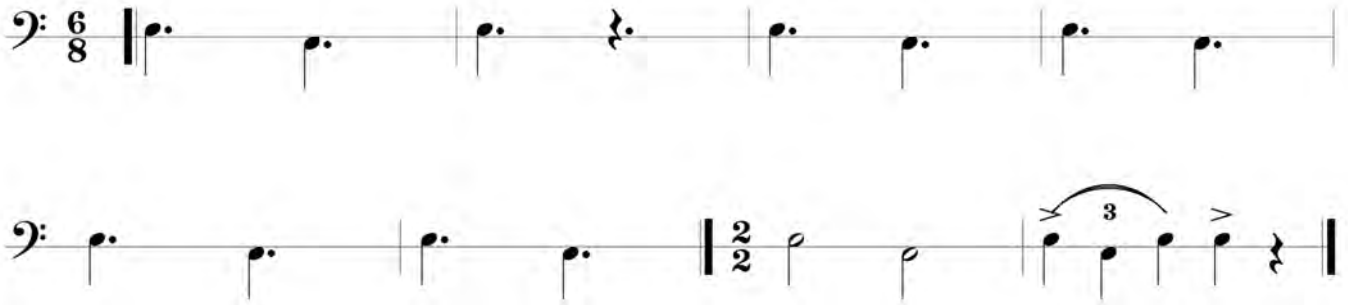

Royal Salute  
Slow Air

*Mallorca*

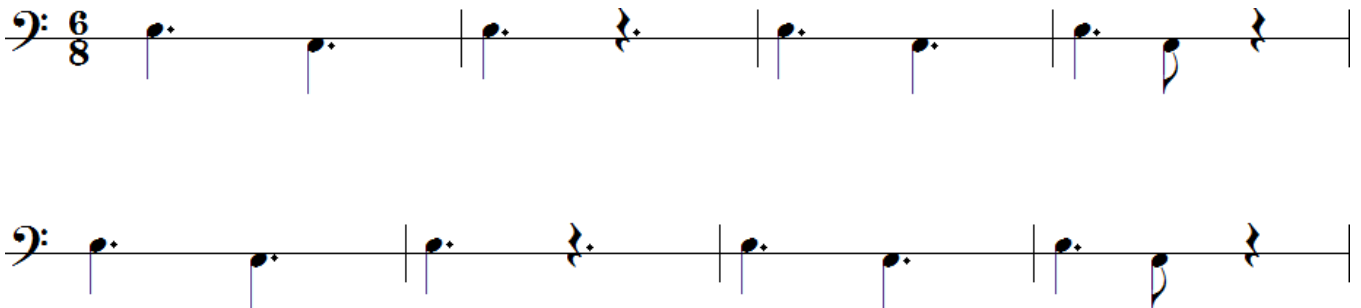

# Vice-Regal and Royal Salute Flourishing Routines

Royal (Vice-Regal) Salute  
Slow Air / March

*Mallorca / O' Canada*

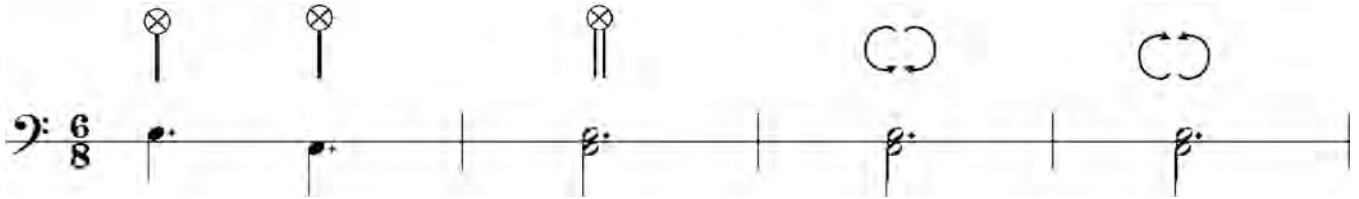

Royal Salute  
Slow Air

*Mallorca*

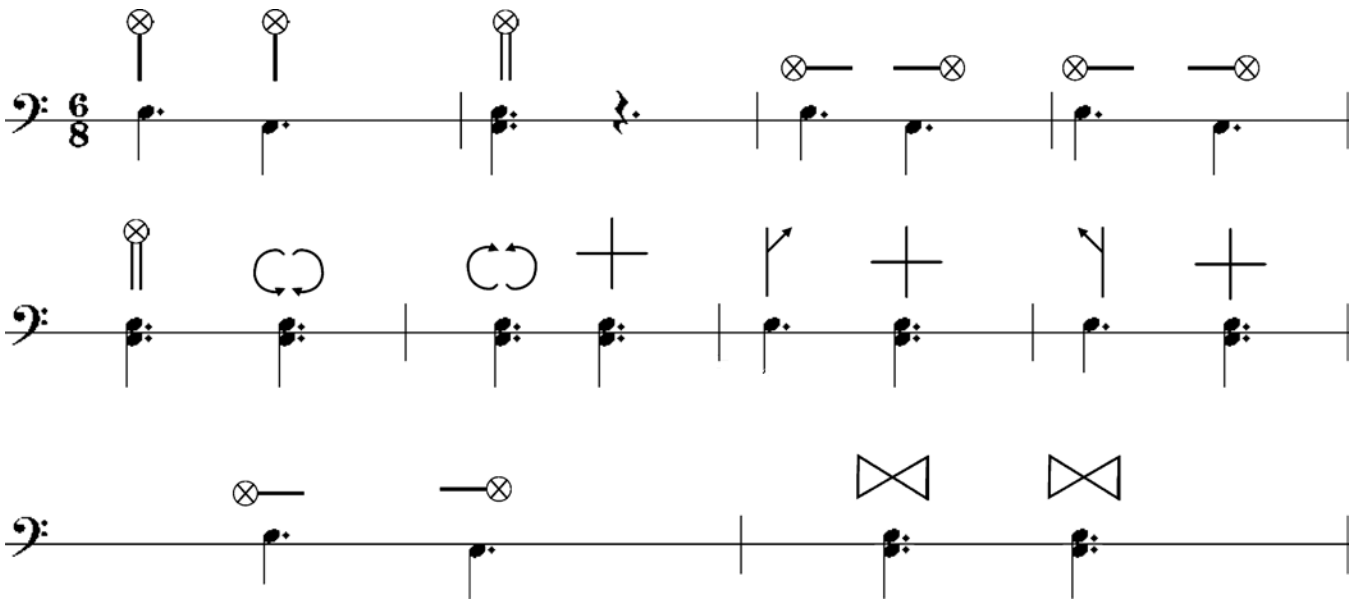

# Welcome to Borden Drum Salute Bass Drum Beating

## Drum Salute

The musical notation is written in bass clef with a 4/4 time signature. The first staff begins with a fermata over the first measure, followed by four measures of rests, and then a four-measure melodic phrase. The second staff contains four measures of rhythmic patterns, each starting with a fermata. The third staff contains four measures of rhythmic patterns, each starting with a fermata. The fourth staff consists of four measures of rests. The fifth staff contains four measures of rhythmic patterns, each starting with a fermata. The sixth staff contains four measures of rhythmic patterns, each starting with a fermata.

*(Continued on next page)*

# Welcome to Borden Drum Salute Bass Drum Beating

(Continued)

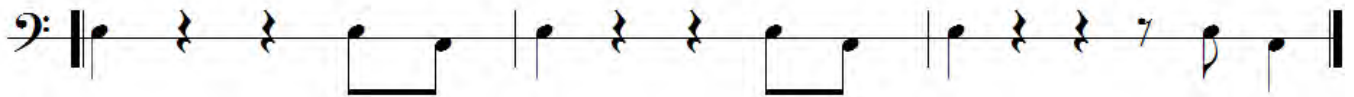
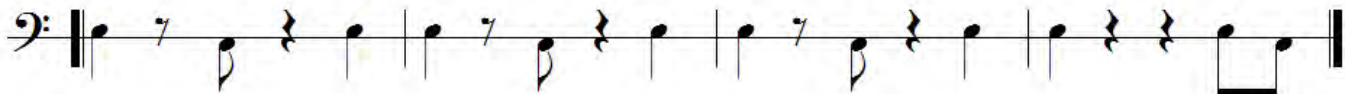
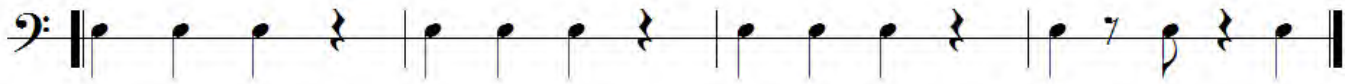
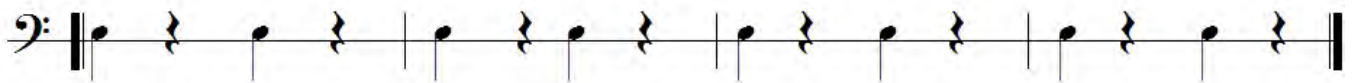
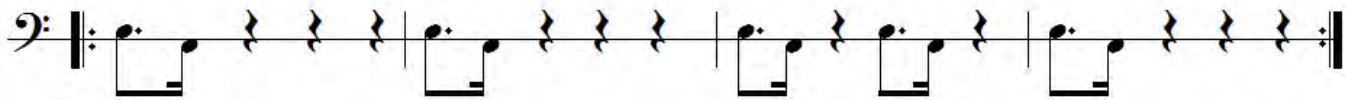
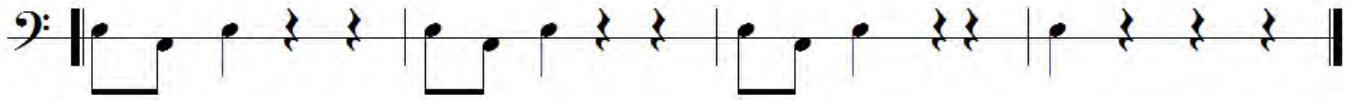
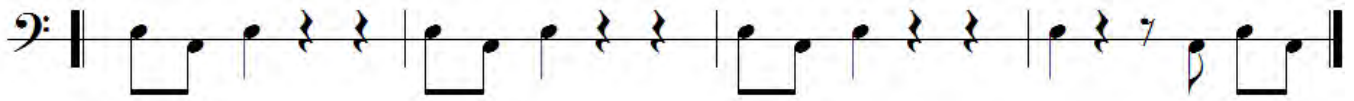

# Drum Salute Flourishing Routine

## Drum Salute

The musical score is written in bass clef and consists of six staves. The first staff is in 4/4 time and begins with a double bar line. The second staff is in 4/4 time and features a series of eighth notes with circled 'X' symbols above them, indicating specific drum strokes. The third staff is in 4/4 time and features a series of eighth notes with circled 'X' symbols above them, indicating specific drum strokes. The fourth staff is in 12/8 time and features a series of eighth notes with circled 'X' symbols above them, indicating specific drum strokes. The fifth staff is in 12/8 time and features a series of eighth notes with circled 'X' symbols above them, indicating specific drum strokes. The sixth staff is in 12/8 time and features a series of eighth notes with circled 'X' symbols above them, indicating specific drum strokes.

*(Continued on next page)*

# Drum Salute Flourishing Routine

(Continued)

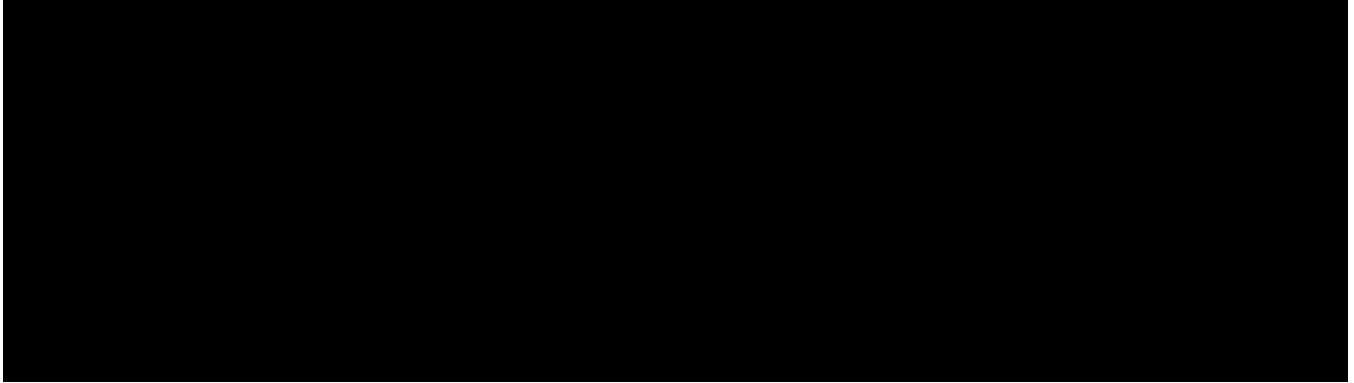

The drum notation consists of four staves in bass clef. The first staff features a series of eighth notes with a circled '8' above a slur, followed by quarter notes and rests. The second staff uses a circled 'X' for cymbal and a circled '8' for snare, with eighth and quarter notes. The third staff includes a circled 'Z' for tom and a circled 'X' for cymbal, with eighth notes and a final eighth note with a cymbal. The fourth staff shows a circled 'Z' for tom, a circled 'X' for cymbal, and a circled 'C' for a cymbal flourish, with eighth notes and a final eighth note with a cymbal.